

# FASTENING

Gearing Mechanisms	2
Structure of Zippers	3
Metal Zippers	4
Plastic Zippers	10
Water Resistant Zippers	18
Clear Zippers	19
Flame-Retardant Zippers	19
Function of Zippers	20
Basic Sliders	20
Decorative Pulls	21
Materials for Zipper Tapes and Elements	22
Dimension Tolerance and Ways of Measuring	22
Zippers for Various Uses	24
Special Features for Safety Requirements	24
Methods to Determine Zipper Strength	25
Strength Standards (Based on JIS)	26
Guide to Effective Use of Metal Zippers	27
Zipper Problems and Countermeasures	28
Proper Use of Zippers	30
Proper Use of Open-end Zippers	32
Sewing "CONCEAL®" Zipper onto Fabric	34
Sewing 3CH(3CC) "CONCEAL®" Open-end Zipper	36
Be Aware of Counterfeit Zippers	37
Ball Chain	38
JOYLON® (Rail Seal Fastener)	40
cosmolon® Hook & Loop Fastener	42
Plastic Hardware	48
Webbing Tape	50
YKK Manufacturing Plants	51
History of Zippers and YKK	52
YKK Worldwide Network	54



## ATTENTION

YKK fastening products include:

- Slide Fasteners
- Ball Chain
- JOYLON<sup>®</sup> (Rail Seal Fastener)
- *cosmolon*<sup>®</sup> (Hook&Loop Fastener)
- Plastic Hardware
- Webbing Tape

- Choose the appropriate item with the necessary strength and durability for your use.
- Please refer to p.25 for methods to determine zipper strength.
- When purchasing, to ensure your needs are met for design or for special applications please consult your YKK sales representatives for information about the characteristics of the fastening products.

※ The photographed colors may vary from the actual products.  
Customers are requested to ask for a sample if color matching is important.

The tapes are adjusted by a slider, the elements are easily engaged due to the gear principle (closed).  
The elements separate when the slider is pulled to the opposite direction (open).

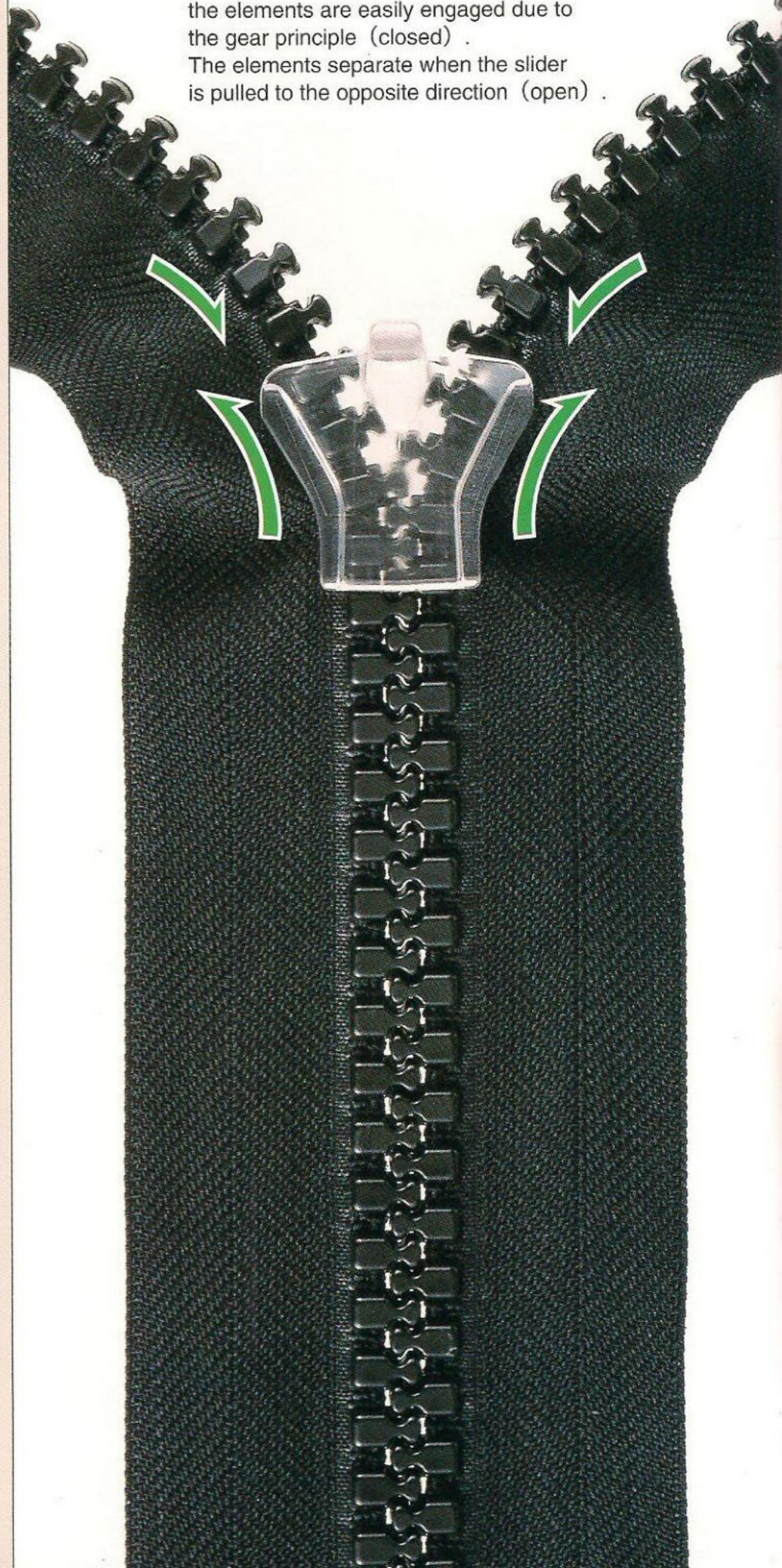



Zippers can be divided into three major parts: the tape, the elements and the slider.

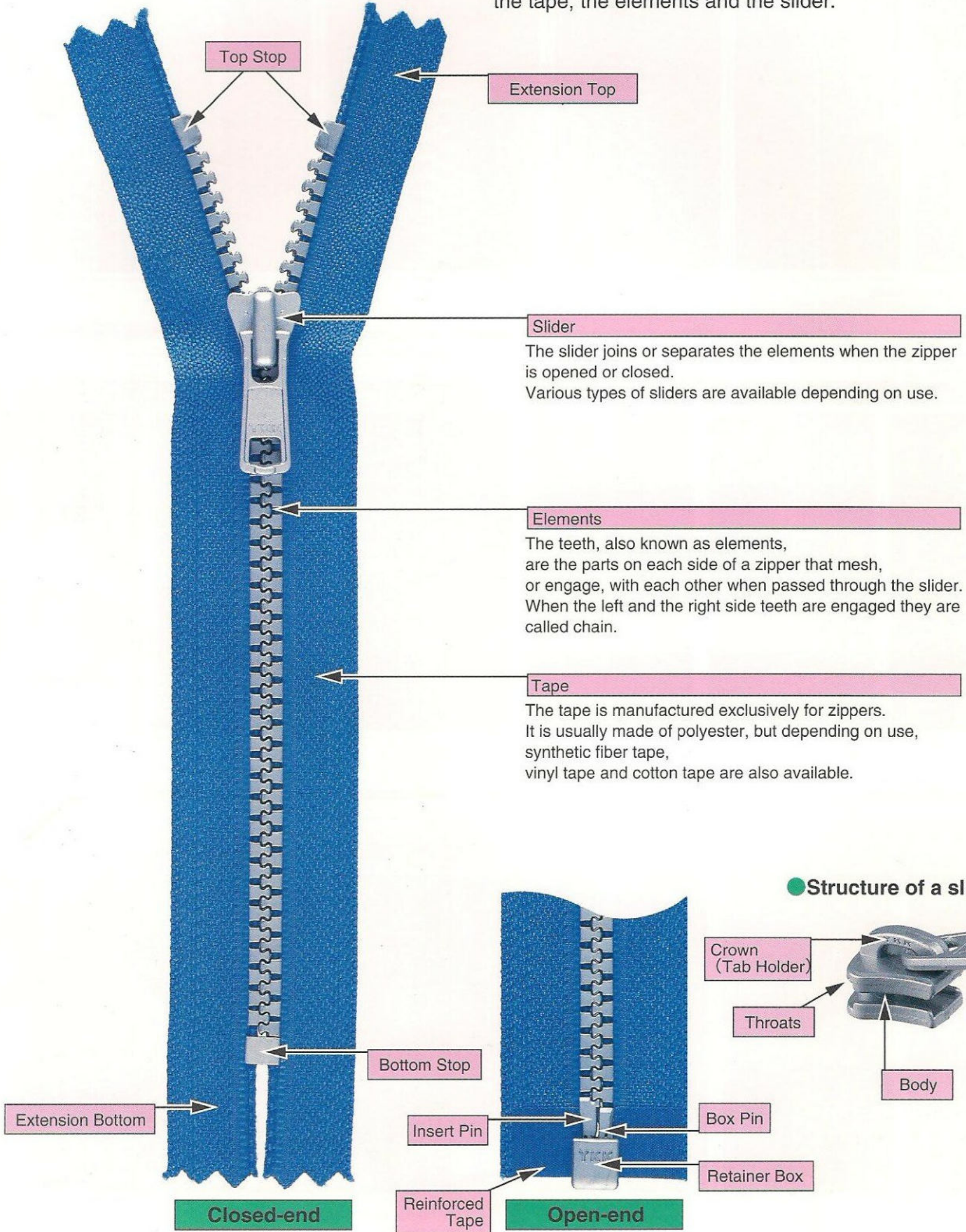

# Kinds of Zippers (Metal Zippers)



**MF (Standard)**

3MG	4MG	5RG	7MG	8MA

Metal zippers Various sizes

**Element Colors**

5RA	5RG	5RGK	5RGKB	5RGTH	5RN
Aluminum	Golden Brass	Black Oxidized	Antique Gold	Antique Silver	Nickel-silver

**Jeans/Trousers Zipper YZiP®**

3YGR	4YG	5YG

It will decolor along with the denim after stonewashing or bleach-out.  
Tape code:CP(Cotton · Polyester) For jeans.

**YZiP® Element Colors**

3YGRK	3YGRKB	3YGRTH

YZiP® Metal zippers Various finishes.  
Tape code:PJR12

The products depicted are actual size.

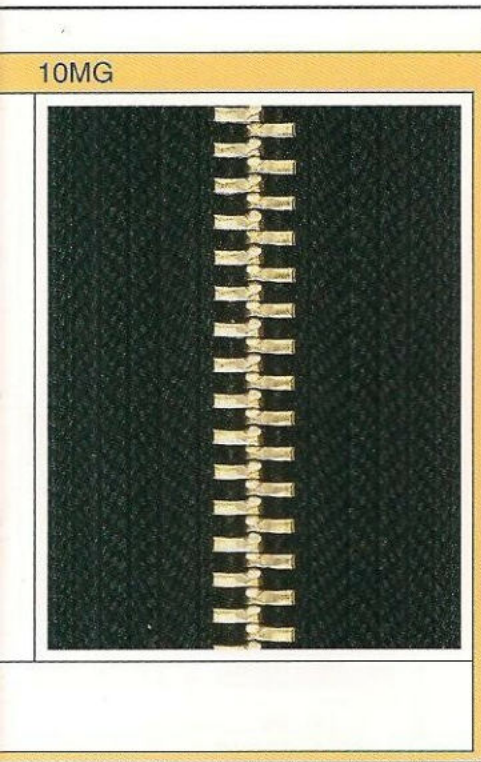

Standard Metal Zippers

Material Size	Aluminum	Golden Brass				Nickel-silver (N)	Anti-Nickel Silver (MN)
	(A)	(G)	(GK)	(GKB)	(GTH)		
2	—	—	—	—	—	N	—
3	MA	MG	MGK	MGKB	MGTH	MN	—
4	MA	MG	MGK	MGKB	MGTH	MN	—
5	RA	RG	RGK	RGKB	RGTH	RN	RMN
7	MA	MG	MGK	MGKB	MGTH	MN	—
8	MA	—	—	—	—	—	—
10	MA	MG	MGK	MGKB	MGTH	MN	—

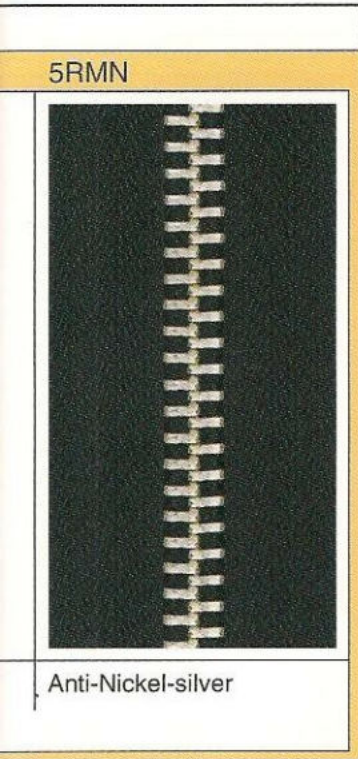

MF Zipper with Double Sliders  
(head-to-head, bottom-to-bottom, two-way separator)

Material Size	Aluminum	Golden Brass				Nickel-silver (N)	Anti-Nickel Silver (MN)
	(A)	(G)	(GK)	(GKB)	(GTH)		
5	RAM	RGM	RGMK	RGMKB	RGMTM	RNM	RMNM
7	MAM	MGM	MGMK	MGMKB	MGMTM	MNM	—
8	MAM	MGM	MGMK	MGMKB	MGMTM	—	MMNM
10	MAM	MGM	MGMK	MGMKB	MGMTM	—	—

● Two-way separator is available only in No.5 · No.10.

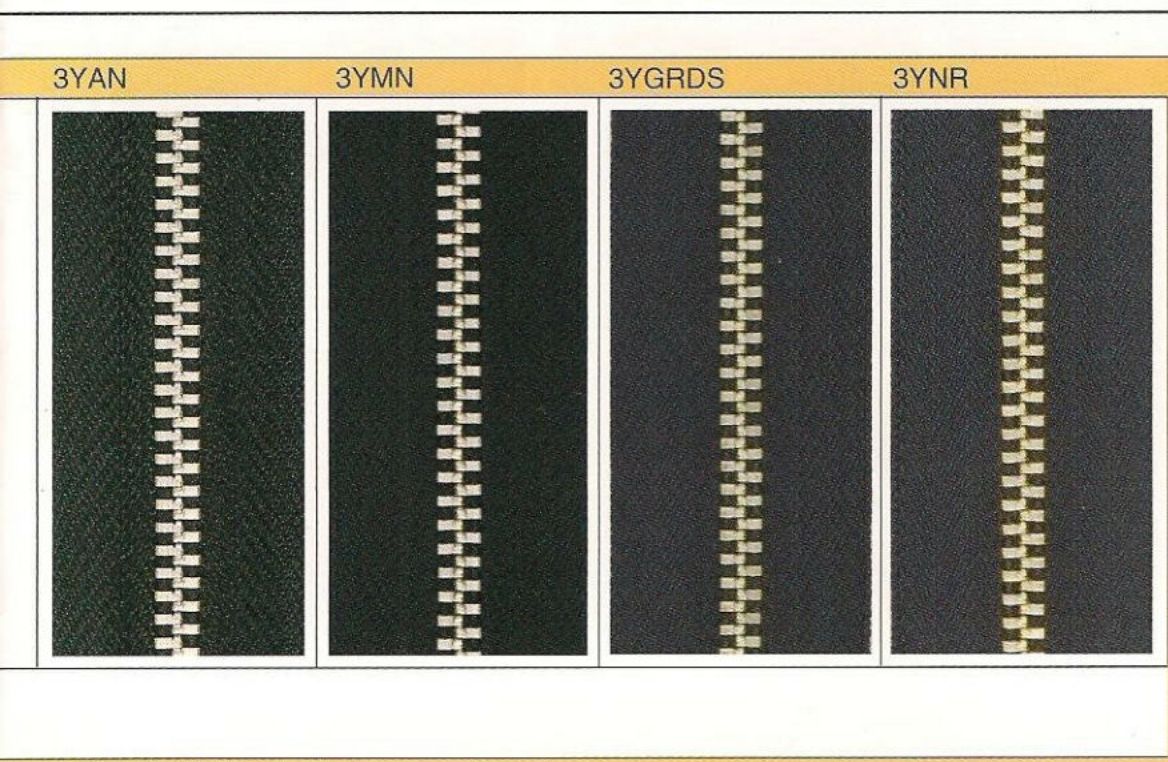

Jeans/Trousers Zipper YZiP®

Surface Finish	Golden-brass	Black	Antique Gold	Antique Silver
Size	G	X6	I	H6
3	YGR	YGRK	YGRKB	YGRTH
4	YG	—	YGKB	YGTH
5	YG	YGK	YGKB	YGTH

Surface Finish	Aluminum	Anti-Nickel Silver	Dull Silver	Nickel-silver
Size			C6	N
3	YAN	YMN	YGRDS	YNR
4	YAN	—	—	—
5	YAN	—	—	YN

# Kinds of Zippers (Metal Zippers)



**EXCELLA® (SG)**

2SGC5	3SGYP	5SGYP	8SGP		5SGWP

Every element of the zipper is polished and plated. Items are available in surface colors including silver, gold, and antique finish.

Double sliders can be used.

## EXCELLA® (SG) Surface Finish Variation

Finish Code	Golden Brass	Nickel	Antique Brass	Antique Silver	Black Silver	Antique Copper	Luxury Gold	Matt White Bronze	Silver	Shiny Black
	OG	P (N)	I	H6	V6	X	Q	C9	C5	X7
Slider Finish in standard	OU	P	I	H6	V6	X	Q	C2/C6	C5	X8
Size	2	SGOG	—	SGI	SGH1	SGV6	SGX	—	SGC5	SGX7
	3	SGYOG	SGYP	SGYI	SGYH6	SGYV6	SGYX	SGYQ	SGYC9	SGYC5
	3	SGWOG	SGWP	SGWI	SGWH6	SGWV6	SGWX	SGWQ	SGWC9	SGWC5
	5	SGYOG	SGYP	SGYI	SGYH6	SGYV6	SGYX	SGYQ	SGYC9	SGYC5
	5	SGWOG	SGWP	SGWI	SGWH6	SGWV6	SGWX	SGWQ	SGWC9	SGWC5
	8	SGOG	SGP	SGI	SGH6	SGV6	SGX	SGQ	SGC9	SGC5
	8	SGWOG	SGWP	SGWI	SGWH6	SGWV6	SGWX	SGWQ	SGWC9	SGWC5

● SG and SGY: one-way zipper, SGW: two-way zipper.

**EVERBRIGHT®**

3MGP	5RGP	7MGP	8MGMP	10MGP

Gloss-polished zippers, are smooth to the touch, glossy, and corrosion-resistant.

The products depicted are actual size.

8SGWP

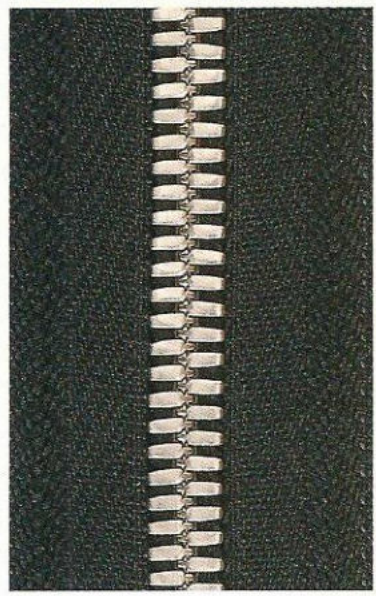

LUMINA® (Alumite Treatment)

3SAWAM

5SAWAM

8SAWAM

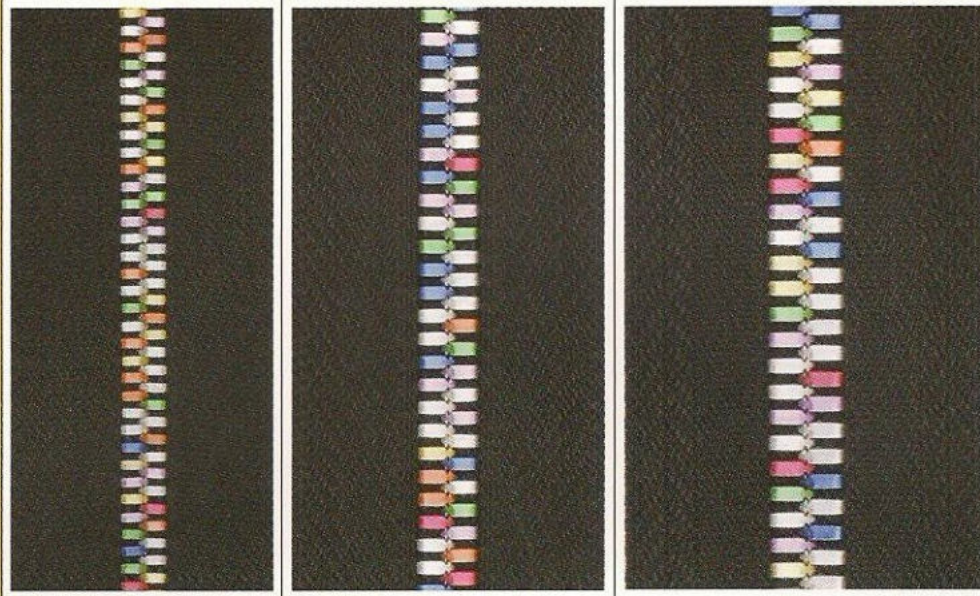

Aluminum EXCELLA® element retains strength, but provides lightweight and color variation.

※See p.6 for details

LUMINA® (SA) Color Variation

Surface Color	Special Feature
Aluminum	—
Golden Brass	EL-GOL3
Antique Brass	EL-GOL4
Black Silver	EL-BLK3
Antique Silver	EL-SIL2
Antique Copper	EL-COP3
Stainless	EL-SIL3
Red	EL-RED2
Orange	EL-ORE3
Purple	EL-VIO3
Green	EL-GRN3
Blue	EL-BLU3
MIX	EL-COM2

Renewal MZF

75MZF

75MZFQ

95MZFN

95MZFK

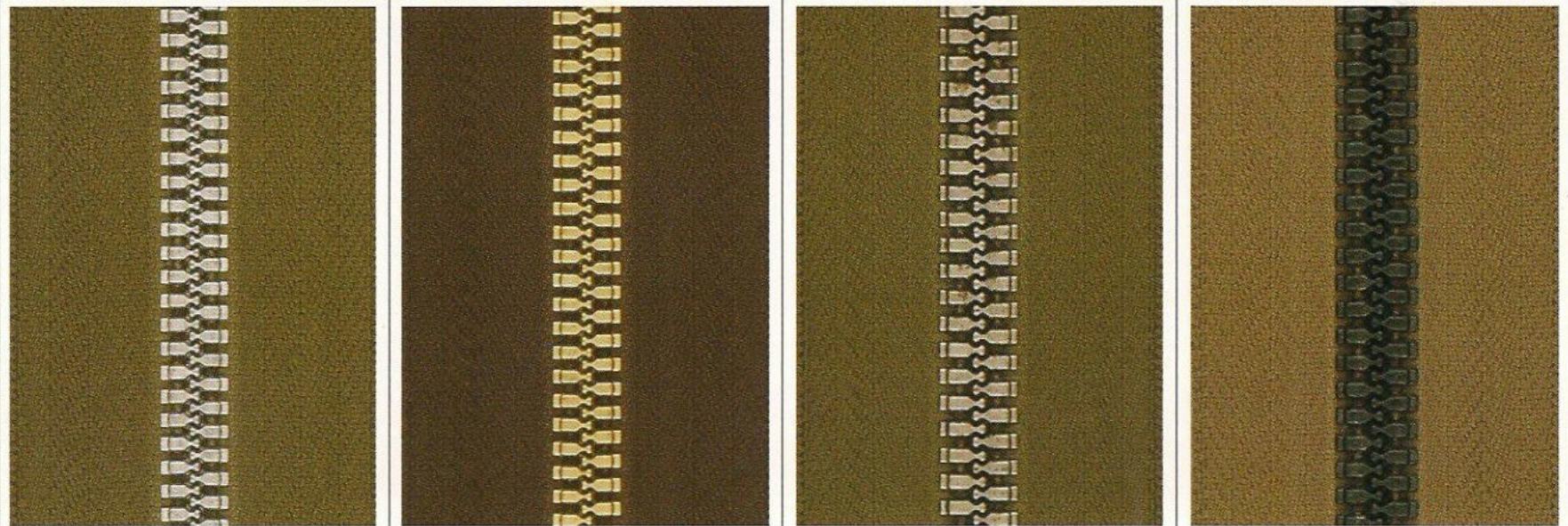

The zipper is made by injection molding zinc alloy.  
 Finished surface: gold, nickel plating, black oxidized, and original surface color.  
 FINGUARD® (with fin)  
 Only size No.75 · 95 available.  
 Double sliders can be used.

Renewal MZF

Surface Finish	Original Surface Color	Gold	Nickel	Black Oxidized
Size	— * Q	N	K *	
75	MZF	MZFQ	MZFN	MZFK
95	MZF	MZFQ	MZFN	MZFK

● \*Slider Finished for the Original Surface Color is "EM703", and "E598" for Black Oxidized.

EVERBRIGHT®

Material	MF			YZiP®		Double Sliders	
	Golden Brass(G)	Nickel -silver(N)	Anti-Nickel Silver	Golden Brass(G)	Nickel -silver(N)	Golden Brass(G)	Nickel -silver(N)
Size	GP	NP	GPS	GP	NP	GP	NP
3	MGP	MNP	—	YGRP	YNRP	—	—
5	RGP	RNP	RGPS	YGP	YNP	RGMP	RNMP
7	MGP	MNP	—	—	—	—	MNMP
8	—	—	—	—	—	MGMP	—
10	MGP	MNP	—	—	—	MGMP	—

# Kinds of Zippers (Metal Zippers)



**Cotton Touch**

3MGKB      5RGKB      7MG

The zipper is natural and soft texture like cotton.  
Tape code:TRP

**Fire Retardant**

5RG

The flame-resistant zipper uses fire retardant tape materials.  
Sizes are No. 5, 7, and 10.  
Cleared by U.S. Federal Aviation Specifications, FAA-25-853 (b)  
See p.19 for details

## Cotton Touch

Element color	Nickel	Gold	Antique Gold
	N	G	GKB
3	—	—	○
5	○	—	○
7	—	○	—

**MARBLE Tape**

5RG      5RGKB      5RN

The marble appearance soft-touch tape is made of mixed yarn containing polyester and rayon.  
The tape color looks slightly different from the ordinary polyester tape.  
Tape code:TR16

**PRIFA®**

5RG      3YGR

Zippers printed with colorful graphic designs.  
\* Original designs are also available.

The products depicted are actual size.



PROSEAL® Watertight/Airtight

4TZN

8TZN

12TZN

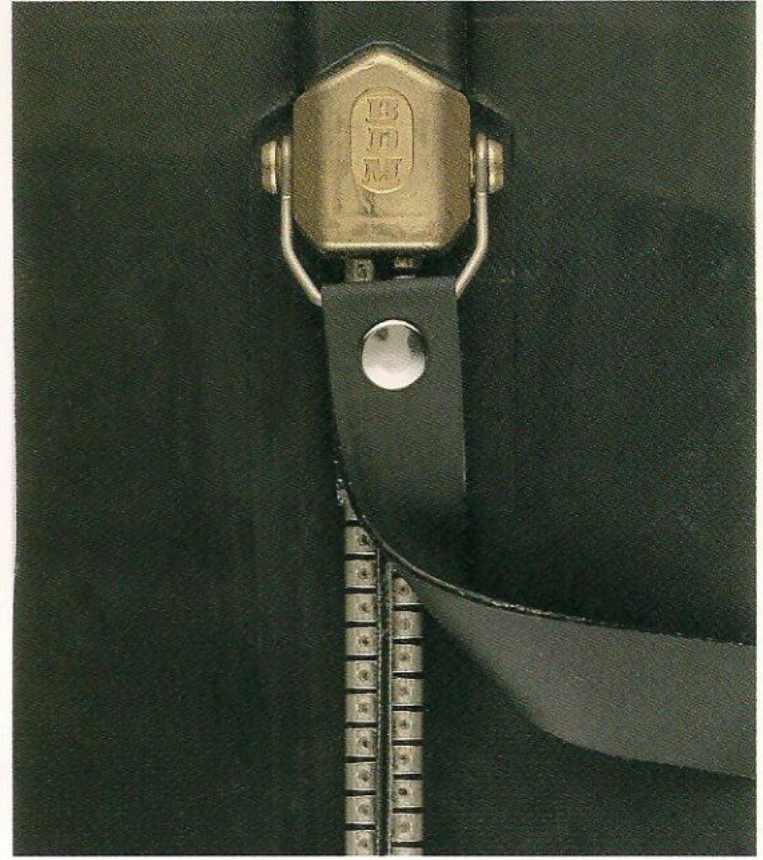
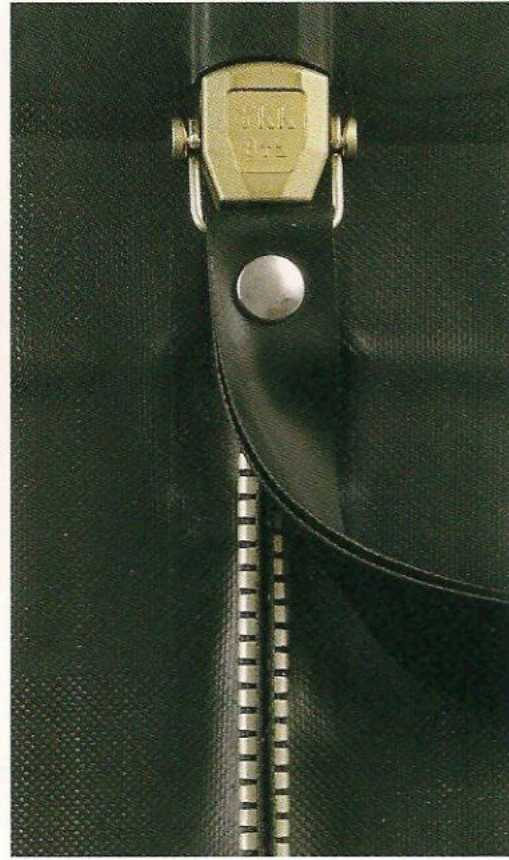

Airtight and watertight zippers  
 Tape materials: PVC, CR(chloroprene rubber), PU(polyurethane)  
 See p.18 for details.

PROSEAL® Watertight/Airtight (AWTIGHT)

Size	4TZN		8TZN			12TZN	
Tape Material	PVC	CR	PVC	PU	CR	CR	
Airtightness	[MPa]	0.0196	0.0294	0.0294	0.0294	0.0687	0.0981
	[kg/cm <sup>2</sup> ]	0.2	0.3	0.3	0.3	0.7	1
Resistance to depth [mts]	2	3	3	3	7	10	

NATULON® (Zipper made of recycled material)

3MG

5RG

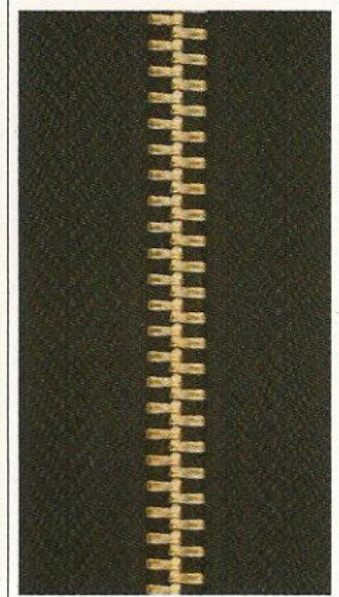
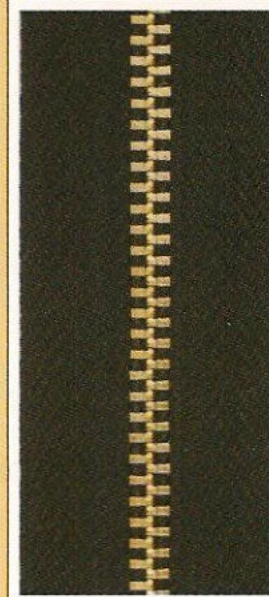

Tape is made of 100% recycled polyester.

NATULON® (Zipper made of recycled material)

Item Spec			Parts Material				
Size	Chain	Zipper End	Tape	Element	Tape	Slider	Top & Bottom Stop / Open Parts
3	MG	C/O	PR12	Brass	Recycled PET	ZAC	Brass / ZAC
5	RG	C/O	PR14	Brass	Recycled PET	ZAC	Brass / ZAC

# Kinds of Zippers (Plastic Zippers)



**Coil (CF)**

2CF	3CF Closed-end	3CF Open-end	45CF	5CNF	8CF

Coil zippers Various sizes

**Woven In Type (EF)**

0EF	4EF	5EF

MINIFA®  
World's smallest zipper.

EFLON®

**FLATKNIT®**

25FK



Zipper with its teeth knitted into the tape.  
Tape code: BP

**Woven In Type (EY)**

65EY

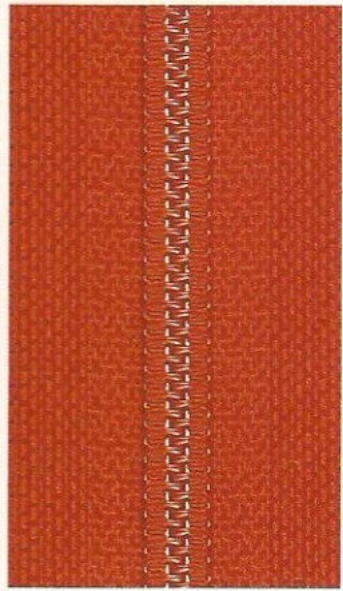

Thin profile and resistant to abrasion.

The products depicted are actual size.

10CF

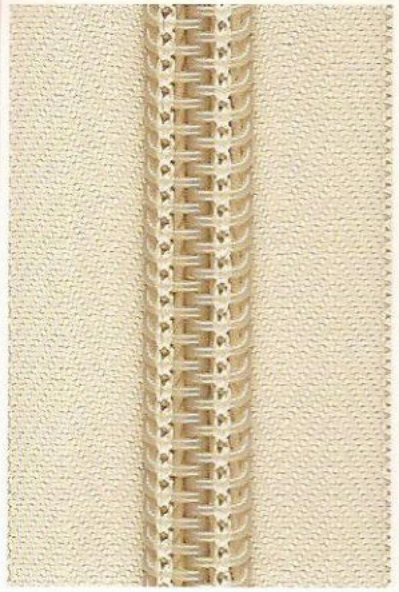

CONCEAL® (CH)

2CH (CC)

3CH (CC)

5CH (CC)

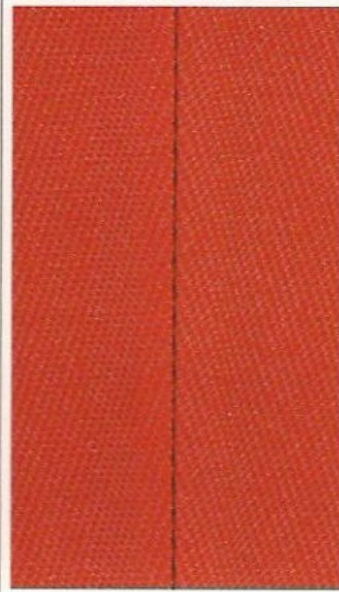

Zipper with concealed elements.

Tape code : BP3

Tape code

: P (Closed - end)

: BP12 (Open - end)

Tape code : PW16

CONCEAL® (Open-end)

3CH (CC)

5CH (CC)

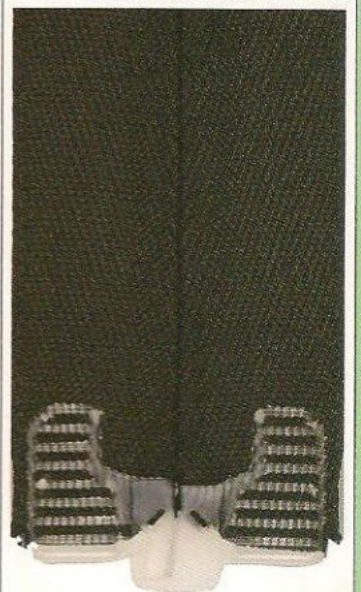

Open-end Conceal® zipper.

GRAPHIC®

3CH (CC)

5CH (CC)

5CNF

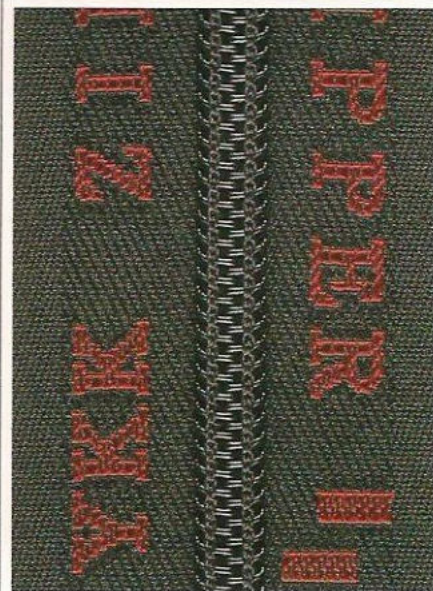
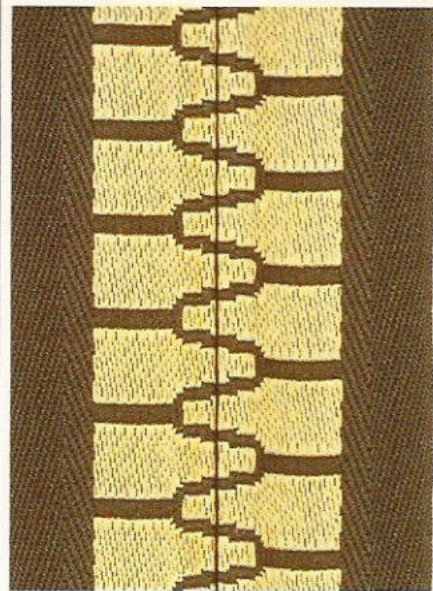

The concealed zipper with jacquard woven design.

Tape code: JA

Tape code: JB

Tape code: JB21

# Kinds of Zippers (Plastic Zippers)



## METALLION®

Element Color	Special Feature	Element Color	Special Feature
Silver	EL-SIL1	Antique Nickel	EL-NIC2
Gold	EL-GOL1	Copper	EL-COP1
Nickel	EL-NIC1	Antique Copper	EL-COP2
Black Nickel	EL-BLK2		

● Please contact YKK sales representatives about the element color.

## REFLECTIVE

Film Color	Special Feature
Silver	REFLX-F
Gold	RFS004D
Translucent	RFS003D
Aurora	RFS007D
Silver line (Single)	ST-SH1
Silver line (Double)	ST-SH2

**METALLION®**

3CM      5CNM

The metal-colored coil-plated zipper

**REFLECTIVE**

5CNF      5CNF (Gold Reflective Film)      5CN (Silver Reflective Line)

(Special Feature: REFLX-F)      (Special Feature: RFS004D)      (Special Feature: ST-SH1)

Reflective film (REFLX-F) is used.

**Clear Coil (CL)**      **CLEAR COIL**

3CL      5CNL      (Clear teeth, pre dyed stitch)

Clear zippers that match with shiny or clear design. Please see P.19 for details.  
Tape code: NM      Tape code: NM2

Zippers with clear teeth having color variations on the sewing thread.  
Tape code: P16N

The products depicted are actual size.

## CLEAR COIL

Sewing Thread Color	Special Feature	Sewing Thread Color	Special Feature
Yellow (#504)	MC-YEL1	Green (#536)	MC-GRN1
Pink (#512)	MC-PIK1	Blue (#542)	MC-BLU1
Pink (#515)	MC-PIK2	Blue (#560)	MC-BLU2
Red (#519)	MC-RED1	Black (#580)	MC-BLK1
Orange (#523)	MC-ORE1	Rainbow	MC-RAB1

● Please contact YKK sales representatives when ordering.

**PRIFA®**

3CF      5CNF

Zippers printed with colorful graphic designs.  
※ Apart from the 35 Standard Designs, original designs are also available.

● Please contact YKK sales representatives when ordering.

## PRIFA®

Size	Chain	Closed	Open
3	CF	○	○
3	CH (CC)	○	
5	CNF	○	○
5	CNT8	○	○
5	CH (CC)	○	

# Kinds of Zippers (Plastic Zippers)



**VISLON® (VS)**

3VS	4VS	5VS	8VS	10VF

INJECTION MOLDED Various sizes

**FINGUARD® (With Fin)**

45VSF	75VSF	95VSF

Fin on the element prevents the slider from catching on the garment.  
Crosswise strength is higher.

**REFLECTIVE**

5VS

Reflective film (REFLX-F) is used.  
Special Feature: REFLX-F

The products depicted are actual size.

**FINGUARD® (With Fin)**

Size	Chain	Closed	Open	Two-way Open
45	VSF	○		
75	VSF	○	○	○
95	VSF	○	○	

**Reflective Zipper**

Size	Chain	Closed	Open
3	VS	○	○
5	VS	○	○

● Please contact YKK sales representatives when ordering.

**REFLECTIVE**

Film Color	Special Feature
Silver	REFLX-F
Translucent	RFS003D
Aurora	RFS007D
Gold	RFS004D

● Please contact YKK sales representatives about tape color.

15VF

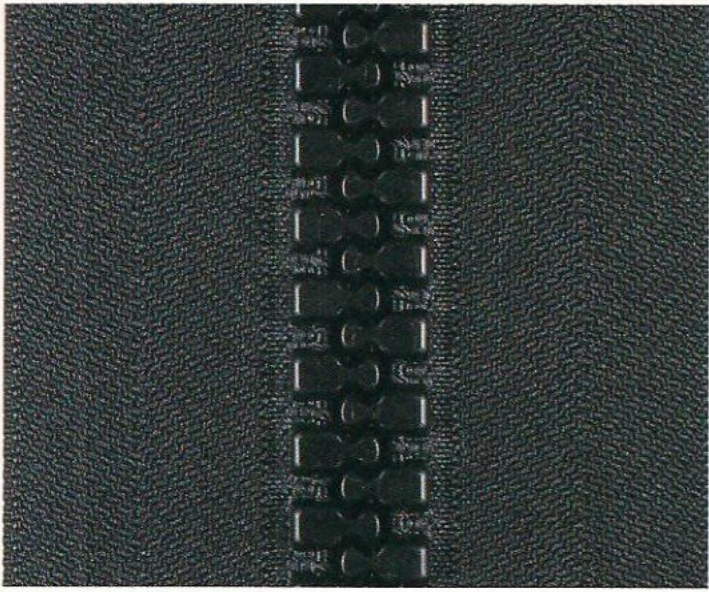

ALUMINUM FLAKE

5VSNL

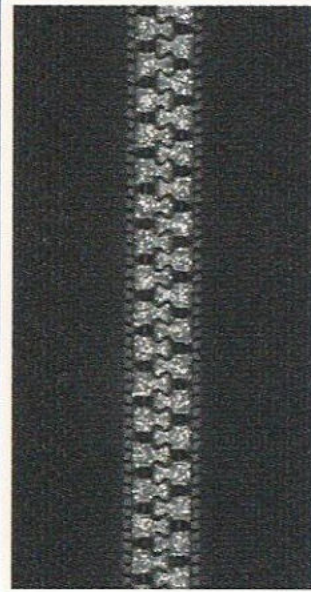

5VSNL (EL-GOL2)



Aluminum powder gives the sparkling impression to the garment.

VISLON® Metallic Colors

VSMB



Antique Gold  
#G765

VSMG



Gold  
#701

VSMJ



Matt Black  
#G770

VSMR



Golden Brass  
#G702

VSMR



Antique Silver  
#G744

VSMV



Silver  
#703

# Kinds of Zippers (Plastic Zippers)



**AQUASEAL®**

5VFWT	10VFWT	10VFWN (PU Tape)
<p>Vislon® typed water resistant zipper. Please see p.18 for details.</p>		

**SEMI TRANSPARENT**

75VSFPH	95VSFPH	75VSFPC	75VSFPC	75VSFPC
<p>FINGUARD®(with fin) Element Material : Polypropylene</p>	<p>A chemical-resistant zipper made solely of polypropylene. (The tape and elements are 100% polypropylene. Only for chains)</p>	<p>Green (X467)</p>	<p>Pink (X469)</p>	<p>Blue (X470)</p>
<p>The element is pastel colored. Please see P.19 for details.</p>				

The products depicted are actual size.

**NATULON®** (Zipper made of recycled material)

Item Spec			Parts Material			
Size	Chain	Zipper End	Element	Tape	Slider	Top & Bottom stops / Open Parts
3	VSPB	C	PBT	Recyclable PET	PBT	POM
4	VSPB	O	PBT	Recyclable PET	PBT	POM
5	VSPB	C/O	PBT	Recyclable PET	PBT	POM

- Finish: EB= Metallic enamel painted  
EW= Standard enamel painted
- VSPB element color: 12 colors (including V color)

**Nylon Tape Zipper**

Item Spec				Parts Material				
Size	Chain	Zipper End	Tape	Element	Tape	Slider	Top & Bottom stops / Open Parts	
5	VS	C	N	POM	N6	ZAC	POM	
5	VS	O	N	POM	N6	ZAC	POM	

- Since the slider is diecasted, please remove it when recycling.
- Top & bottom stops: upper = top stop, bottom = bottom stop
- POM means polyacetal.
- ZAC means zinc alloy.

**NATULON®** (Zipper made of recycled material)

3VSPB      4VSPB      5VSPB

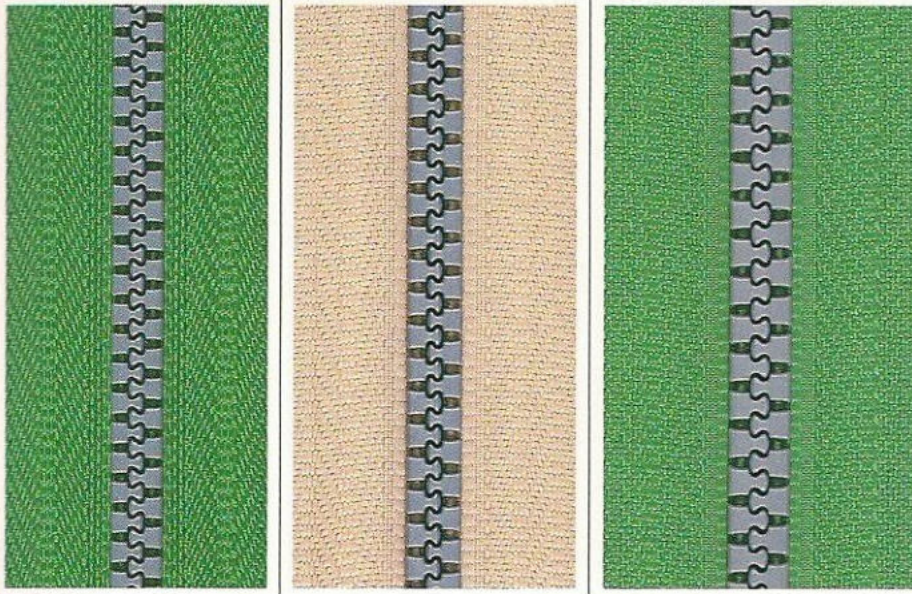

Tape is made of recycled polyester.  
Elements are made of polyester.

**Nylon Tape Zipper**

5VS

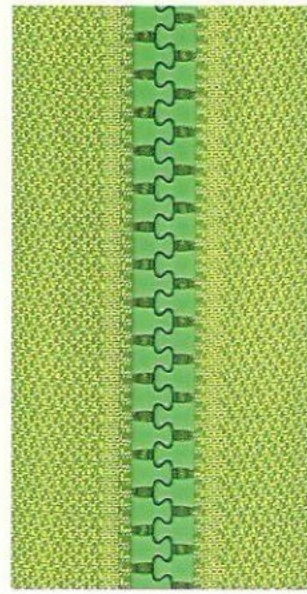

Tape is made of 100% Nylon.

**TRANSPARENT (VSNT)**

5VSNT      8VSNT

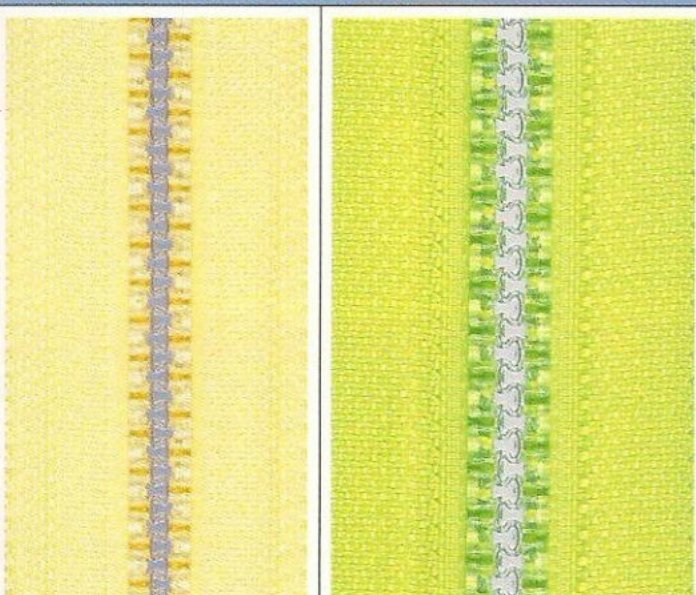

Its appearance is clear and natural since the element is made of Nylon.  
Please see P.19 for details.

**LUMIFINE®**

5VSK

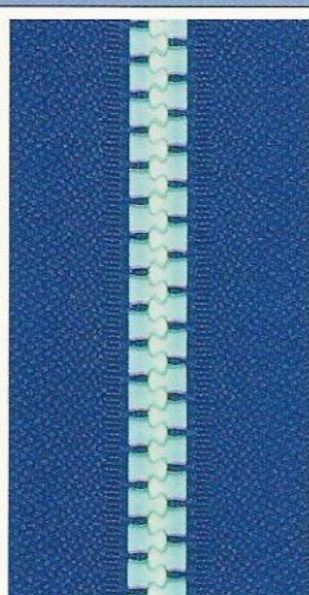

The light-accumulating zipper glows in the dark.

TRANSPARENT VISLON®			
Element Color	Special Feature	Element Color	Special Feature
Semi-clear	EL-HAN	Orange	EL-ORE2
Grayish Yellow	EL-YEL2	Khaki	EL-BRW1
Carbon	EL-BLU2	Black	EL-BLK1
Grayish Blue	EL-BLU3	Gray	EL-GRY1





# Water Resistant Zippers



● Please contact YKK sales representatives when ordering.

## AquaGuard® (Water Repellent Zipper)

Chain	Characteristic	Usage	Storage Precaution	Usage Precaution
3CFT8 5CNT8 5CNT9 5CNT10 ※ Please see p.13 for details	The tape is laminated with polyurethane for high water repellency.  Tape available in 24 standard colors.	● Outdoor Wear/equipments	● Keep zippers away from direct sunlight when storing to prevent yellowing problems. ● Avoid storing with other materials to prevent the migration (color transfer) problem. ● This is a water-repellent zipper and not completely water-resistant. ● Slider types are limited since this item uses the back-side chain. ※ For more information contact the YKK sales representatives	● Close the zipper completely when washing. Let it dry naturally. ● Specify the petroleum-type dry-cleaning. Chlorine-type dry-cleaning may worsen the zipper operability or may cause cloudiness on the chain surface. ● Prolonged tumble-dry with excess load may cause film damage on the chain. ● Do not iron the zipper. ● Avoid direct contact with PVC or PU products to prevent the migration (color transfer) problem.
	 <p>3CFT8</p>			
	 <p>5CNT8</p>			

## Aquaseal® (Waterproof Zipper)

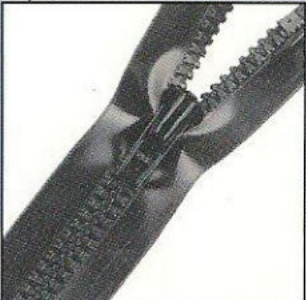
Chain	Characteristic	Usage	Storage Precaution	Usage Precaution
5VFWT 10VFWT 10VFWN ※ Please see p.16 for details	Vision type waterproof zipper.  Slider operability improved so overall operation smoothness was achieved.	● Wet suit ● Water proofed bag ● General purpose materials	● Rinse off any object attached on both sides of the zipper, taking care not to bend the zipper. ● Do not place any heavy object on the zipper. ● Store away from heat and moisture.	● Slowly move the slider when operating. Angular pulling may cause element mis-engagement and may result in poor waterproof performance or zipper damage. ● <b>Do not apply excess load to the bottom stop when operating the zipper or it may damage the stop or the zipper. Provide appropriate reinforcement at the stop part.</b> Please consult YKK representatives for further advice.
	 <p>10VFWT</p>			

## PROSEAL® (Water & Air Tight Zipper)

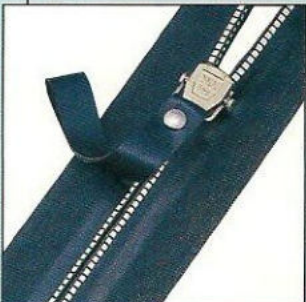
Chain	Characteristic	Usage	Storage Precaution	Usage Precaution																				
4TZN 8TZN 12TZN ※ Please see p.9 for details	The zipper shuts out both water and air when completely closed.  Airtightness (depth of water)	● Dry suits ● Survival suits (immersion suits) ● Liquid Containers	● Rinse both sides of the zipper and brush off any object attached. ● Store with the zipper completely opened, taking care not to bend it. ● Do not place any heavy object on the zipper.	● Thoroughly rinse or brush off any object (sand, mud etc.) attached in/outside of the elements before operating the zipper, or it may result in poor tightness performance or may damage the zipper. ● Slowly pull the slider pull-tab when operating. Angular pulling may cause element mis-engagement and may result in poor tightness performance or may damage the zipper. ● Close the zipper till the slider completely touches the stop to ensure the tightness. ● Do not use in the environment where water temperature is under 10°C as the PVC becomes hardened and affects the tightness performance. ● Due to the PVC character, tightness of the PVC item will deteriorate over time. ● By prolonged contact with such surface materials as PVC or synthetic leather, PVC may react with their processing additives and the migration (color transfer) problem may occur. Avoid direct contact when storing by placing a sheet of paper between the zipper and the material.																				
	<table border="1"> <thead> <tr> <th></th> <th colspan="2">4TZN</th> <th colspan="2">8TZN</th> </tr> <tr> <th>Tape material</th> <th>PVC</th> <th>CR</th> <th>PVC</th> <th>CR</th> </tr> </thead> <tbody> <tr> <td>Airtightness [kg/cm<sup>2</sup>]</td> <td>0.2</td> <td>0.3</td> <td>0.3</td> <td>0.7</td> </tr> <tr> <td>Resistance to depth (mts)</td> <td>2</td> <td>3</td> <td>3</td> <td>7</td> </tr> </tbody> </table>		4TZN		8TZN		Tape material	PVC	CR	PVC	CR	Airtightness [kg/cm <sup>2</sup> ]	0.2	0.3	0.3	0.7	Resistance to depth (mts)	2	3	3	7			
	4TZN		8TZN																					
Tape material	PVC	CR	PVC	CR																				
Airtightness [kg/cm <sup>2</sup> ]	0.2	0.3	0.3	0.7																				
Resistance to depth (mts)	2	3	3	7																				
	 <p>8TZN</p>																							

# Clear Zippers



● Please contact YKK sales representatives when ordering.

Name	Chain	Characteristic	Usage	Usage Precaution
Coil Zipper with Clear Tape	3CL 5CNL	As the tape is made of nylon monofilament, it can be well matched with the clear or thin fabric.	● Apparel	<ul style="list-style-type: none"> <li>● Specify the petroleum-type dry-cleaning.</li> <li>● As the tape is made of nylon monofilament, the crosswise strength of the tape is slightly lower than that of standard tape.</li> <li>● Wash with water temperature under 40°C to prevent the nylon tape from shrinking.</li> <li>● Iron with the low temperature (80 – 120 °C).</li> </ul>
(Semi-) Transparent Vislon® Zipper	5VSNT 8VSNT	Clear elements can give softer and more natural appearance and can highlight the color of the fabric.	● Apparel, Luggage	<ul style="list-style-type: none"> <li>● Specify the petroleum-type dry-cleaning. (Chlorine-type dry-cleaning may worsen the zipper operability.)</li> <li>● Avoid the application subjected to heavy load, as the chain strength is slightly lower than that of standard chains.</li> </ul>
	75VSFPH 95VSFPH 75VSFPC	Elements are made of PP (polypropylene). (95VSFPH has the special specification of "all PP" for chemical-resistant application. * Chain Supply Only)	● Apparel, Luggage	

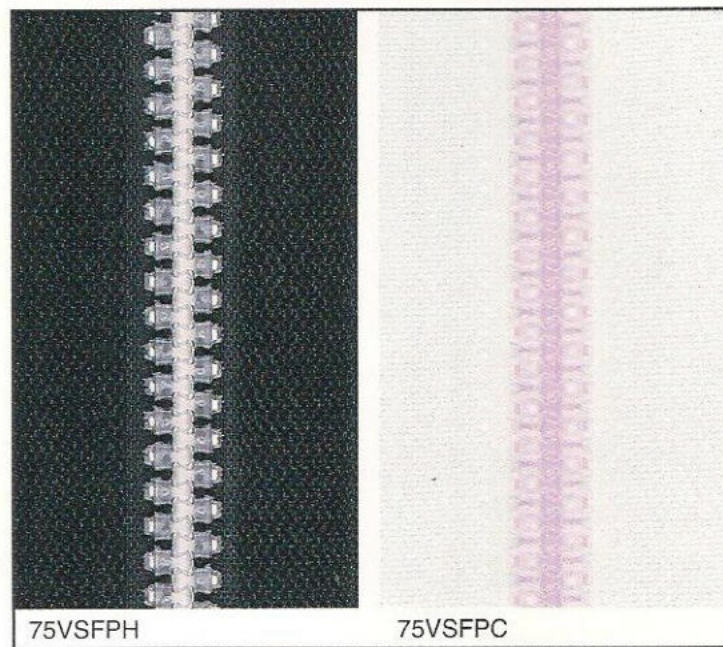
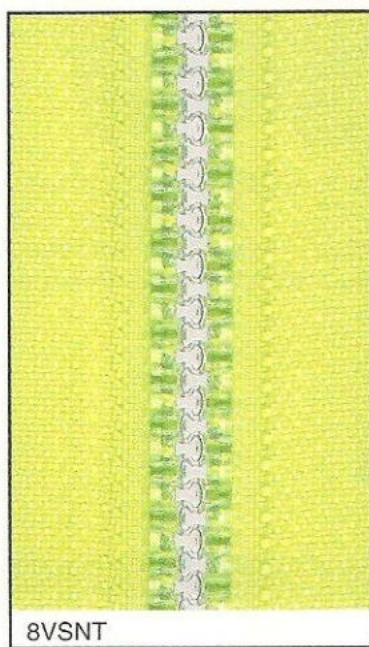
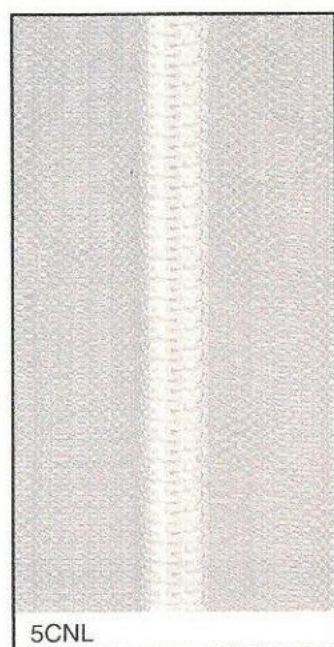

# Flame Retardant Zippers



● Please contact YKK sales representatives when ordering.

Standards for flame-resistance	Zipper	Usage
<b>FMVSS 302</b> US Federal Motor Vehicle Safety Standard	3CF 45CF 5CNF ※Please ask the sales staff about usage as flame-resistant zippers have been given special treatment.	● Automotive Industry
<b>FAR 25-853</b> US Federal Aviation Regulation	Metal zippers with CONEX® tape Size : 5、7、10.	<ul style="list-style-type: none"> <li>● Racing suits</li> <li>● Flight jackets</li> </ul>

"CONEX®" is a registered trademark of TEIJIN.





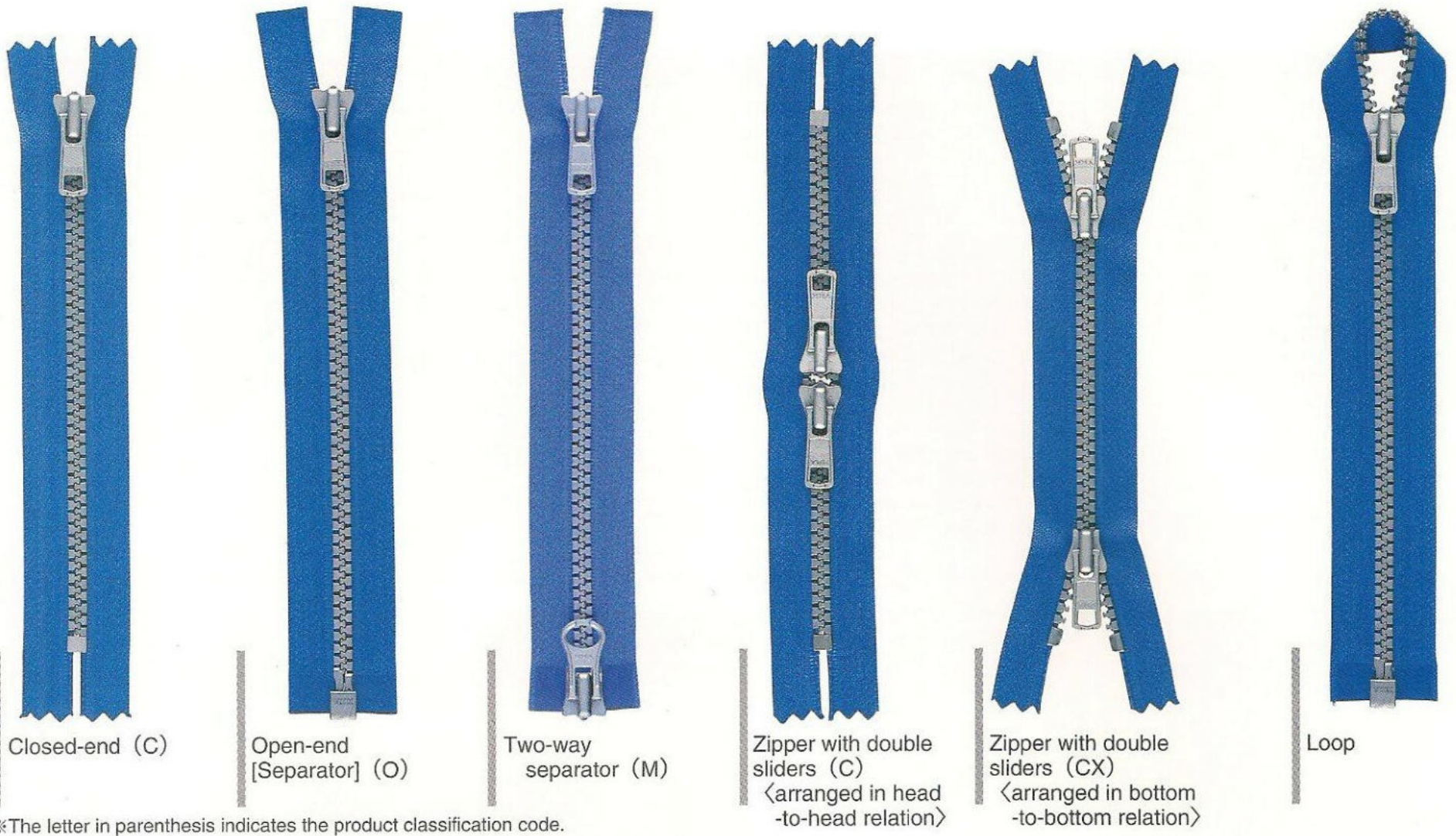

# Function of Zippers

## By Function









## Basic Sliders

●Slider catalogue is also available.

Non-Lock Slider	Automatic Lock Slider	Semi-Automatic Lock Slider	Jeans Slider	Pin Lock Slider	Reversible Slider	Plastic Slider
						
DF	DA	DS	GS	DP	DU	TA
This slider has no locking mechanism.	The locking mechanism automatically functions when the pull-tab is released.	The locking mechanism functions when the pull-tab is snapped down.	Semi-automatic lock slider for Jeans.	Pin(s) on the pull-tab sets between the elements to function as a lock.	The pull-tab moves along the rotating rail, enabling the operation from both sides. (Automatic Lock type)	Plastic automatic-lock slider

Snap-On Sliders		Clip-On Sliders		GA Slider	Key-Lock Slider
					
ZF	ZA	CF	CA	GA	
(Non-lock)	(Automatic)	(Non-lock)	(Automatic)	Brass slider for marine wear. (Automatic-Lock type)	Can be locked with a key.
A pull-tab can be attached to the slider later.					



Top Open





SnapTrak®



Side Open



Plastic Slider	Double-Pulled Sliders	
 <p data-bbox="272 1887 314 1921">TF</p>	 <p data-bbox="553 1887 595 1921">DX</p>	 <p data-bbox="840 1887 883 1921">DW</p>
<p data-bbox="53 1932 308 1966">Plastic non-lock slider.</p>	<p data-bbox="336 1932 600 2067">The pull-tab is attached on both sides of the slider, enabling the operation from both sides. (Automatic Lock type)</p>	<p data-bbox="617 1932 902 2067">The pull-tab is attached on both sides of the slider, enabling the operation from both sides. (Non-Lock type)</p>



# Materials for Zipper Tapes and Elements



Different tape/element materials are available depending of the application and usage.  
 Different sewing method or materials to which the zipper is applied may require different material even if zippers are used for the same purpose.  
 Please refer to the following table when specifying the material.

## Material of Element

Item	Element
MG/RG/YG	Golden Brass
MA/RA/YA	Aluminum
MN/RN/YN	Nickel-silver
CF	Polyester
EF	Nylon
CH (CC)	Polyester
VS	Polyacetal

## Material of Special Tape

Usage / Spec.	Material of Tape	Item
Standard	Polyester	
For Welding	Polyester (Film-laminated)	*
	Cotton	*
Elastic (Vertically)	SPANDEX	5CNF
Chemical Resistant	Polypropylene	95VSFPH
For Jeans	Polyester	3Y · 4Y · 5Y (G, N)
	Mixed Weaving of Polyester/Cotton	
Cotton Touch	Mixed Weaving of Polyester/Rayon	5M*
Jaquard	Mixed Weaving of Polyester/Rayon	3CC · 5CC · 5M *
Rail-Seal Fasteners	Polyvinyl Chloride (PVC)	See p.41
	Olefin	
Water & Air Tight Zipper	Chloroprene Rubber (CR)	See p.9
	Polyvinyl Chloride (PVC)	
AquaGuard®	Polyester (PU coated)	See p.13
Flame Resistant	CONEX®	5M · 7M · 10M
Heat Resistant	NASLON®	5M
For Electromagnetic Waves	NASLON® + CONEX®	5M

"CONEX®" is a registered trademark of TEIJIN.

"NASLON®" is a registered trademark of NIPPON SEISEN.

\* Please contact YKK representatives.

# Dimension Tolerance and Ways of Measuring



When measuring a zipper, completely close it.  
 The indicated zipper dimension has the specified tolerance as follows:

Product Dimension	Maximum Tolerance
≤ 300 mm	±5mm
300 mm < D ≤ 600 mm	±10mm
600 mm < D ≤ 1200 mm	±15mm
1200 mm <	±2.0%

※Maximum tolerance for Metal zippers and Vislon zippers vary.

※For special products or products with special conditions affecting the dimensions, the above tolerance may not apply.

(as per JIS-S3015)

\* Different tolerance is applied depending the types of the zippers.

\* Some special products may not meet the above tolerance.



## Standards for Measuring Zipper Dimensions

(Based on JIS-3015)

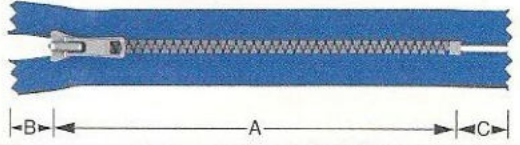
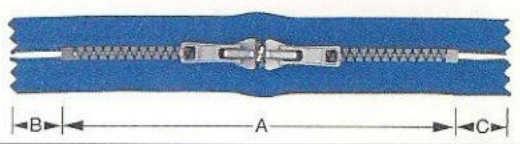
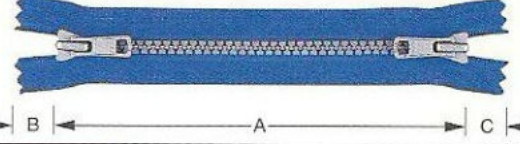
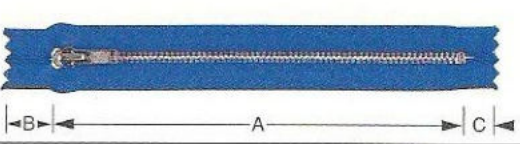
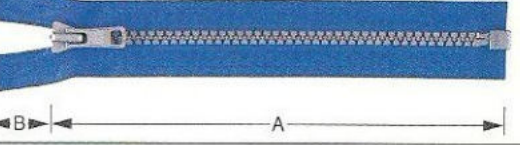
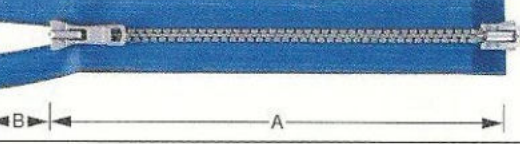
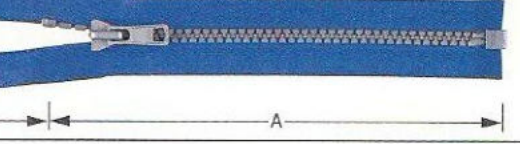
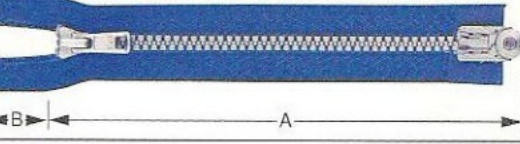
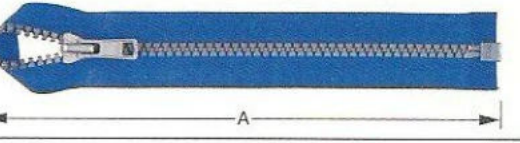
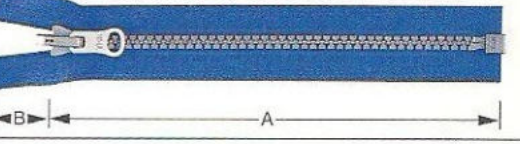
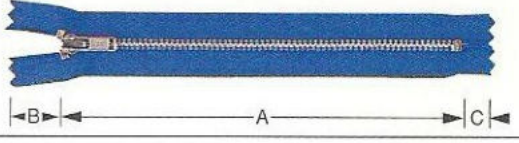
Zipper Type	Zipper Length Length (A)	Top Extension Length (B)		Bottom Extension Length (C)
■ Closed-end	Slider Top End to Bottom-stop End	Upper Top Stop End to the tip of the notches of the cut end		Bottom Stop End to Jagged Tape Tip
■ Closed-end with Double Sliders (Head to Head)	One Bottom-stop End to The Other Bottom-stop End	Upper Bottom Stop End to Jagged Tape Tip		Bottom Stop End to Jagged Tape Tip
■ Closed-end with Double Sliders (Bottom to Bottom)	One Slider Top-end to The Other Slider Top-end	Upper Top Stop End to Jagged Tape Tip		Same as Top Extension Length
■ Closed-end with Bridge Top Stop	Bridge-stop End to Bottom-stop End	Bridge Stop End to Jagged Tape Tip		Bottom Stop End to Jagged Tape Tip
■ Open-end	Slider Top-end to Separating-unit End	Upper Top Stop End to Cut Tape Tip		
■ Two-way Separator	Slider Top-end to Bottom End of Reinforced Tape	Upper Top Stop End to Cut Tape Tip		
■ Top-open	Top-stop End to Separating-unit End	Top Stop End to Cut Tape Tip		
■ SnapTrak®	Slider Top-end to Separating-unit End	Upper Top Stop End to Cut Tape Tip		
■ Loop	Top-element Head to Separating-unit End			
■ With Reversible Slider	Throatinlet Portion of the Slider to Separating Unit End	Upper Top Stop End to Cut Tape Tip		
■ If Top Stop does not fit in Slider	Top-stop End to Bottom-stop End	Upper Top Stop End to Jagged Tape Tip		Bottom Stop End to Jagged Tape Tip



Usage	Zipper Items	Notes
Skirts or dresses	2CH (CC), Closed-End with DA Slider 25FK, Closed End with DA Slider	※Please use automatic lock sliders.
Men's trousers	4EF, Closed-End with DA Slider	
Jeans bottoms	3YGR, Closed-End with GS Slider 4YG, Closed-End with GS Slider 5YG, Closed-End with GS Slider	※For fabric up to 12 ounces ※For fabric over 12 ounces ※For fabric over 12 ounces ※Please use semi-automatic lock sliders. ※Specify the GS slider if applying such after-processing as washing.
Jackets (front)	Size No. 4 or Larger Metal (MF) & Plastic (CF & VS), Open-End with DA Slider	※Please use automatic lock sliders.
Jackets (pockets)	Size No. 3 & No. 4 ○Metal (MF) & Plastic (CF & VS), Open-End with DA or DF Slider ○3CH (CC) Graphic®	※A Wide range of slider pull-tab can be attached by using CA-type (clamper clip-on) slider.  ※Original logos or designs can be applied onto the zipper tape

## Special Features for Safety Requirements.



### ■ KENSIN® : Needle-Detection Standard Compliant Items

Class	Steel Ball $\phi$
NC-A	Under $\phi 0.8$

The needle detection machine reacts to magnetic metals (e.g., iron, nickel) in particular. However, even non-magnetic metals (e.g. copper, aluminum, brass) may be detected by eddy current caused by the articles being moved from one place to another during the detection process. YKK has researched and developed materials, surface treatment, strength, and design of zippers, to prevent false needle detection.

※Please ask YKK representatives for products that comply with the needle detectors.

### ■ N-ANTI : Anti-Nickel Compliant Items

The European Directive 94/27/EC restricts the introduction of the products, coming into direct and prolonged contact with skin, and from which the rate of nickel release is over 0.5ug/cm<sup>2</sup>/week, to the market. YKK provides products with a lower nickel level than criteria as Anti-Nickel Compliant products upon request.

### ■ NEWKOB4 : Top Stop Preventing the Slider Pulled-out Problems on Vislon® Open / Two-way Open Zippers

YKK believes that any parts used for children's products that could possibly be swallowed by children should not be easily detached from the main part of the product.

YKK works to provide safety & security with our products and we reflect this policy at the design stage to develop some top stops to prevent sliders from being pulled off from the zipper chain.

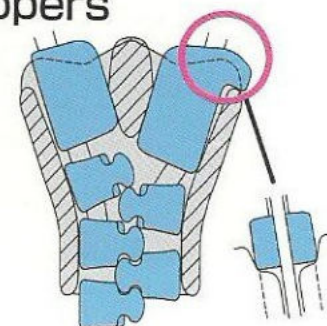

# Methods to Determine Zipper Strength



There are various ways to evaluate the zipper strength.

Basic strengths are determined by the following tests (based on JIS S 3015:2007) then appropriate application for each item is determined.

※Tensile Testing Machine Conditions --- Tensile Speed: 300 mm/min, Clamp Width: 25 mm

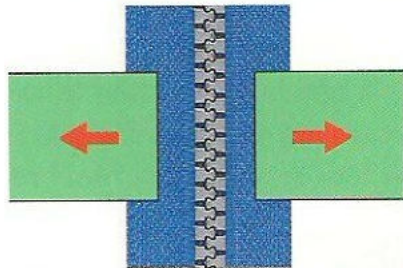

## ●Chain Crosswise Strength (per 2.5cm width)

An engaged zipper chain is pulled crosswise as shown at a constant speed.

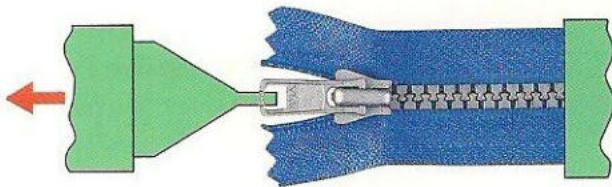

## ●Top Stop Holding Strength

The lower part of an engaged zipper is held securely then the slider pulled at the uppermost is further pulled up.



## ●Bottom Stop Holding Strength

The slider is pulled down to the bottom stop and each side of the chain is pulled out to each direction.

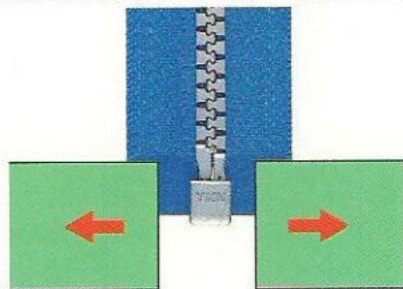

## ●Separating Unit (Open Parts) Crosswise Strength

Only open parts are set at the clamp of the tensile testing machine and pulled crosswise.



## ●Slider Locking Strength

The slider lock is engaged in the middle of a chain then each side of the chain is pulled out to each direction.

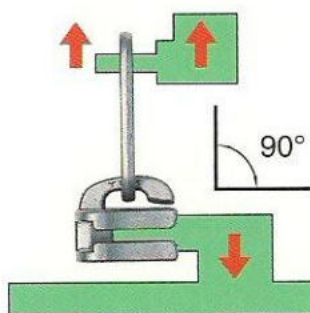

## ●Slider Mouth & Pull Holding Strength (90°)

Tension force is applied to both the pull-tab and the body bottom of an assembled slider.  
In addition to the shown 90° angle, 45° angle is also tested.  
(Tensile Testing Machine Speed: 100 mm/min)

Besides above JIS strength tests, YKK zippers meet BS reciprocating endurance requirement.





## YKK zippers meet all the JIS requirements

When selecting zippers, please check the strength required for the intended application. YKK also sets its own quality standards to produce and provide better quality products. Even items meeting the same JIS class have different strengths per item so please contact YKK representatives for more detailed specifications.

● Zippers are classified according to their chain width (i.e. the width of the engaged elements).

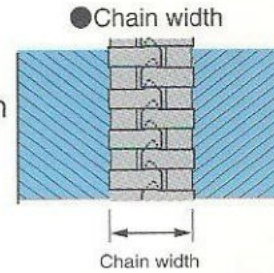

### JIS Classification

Class	Code	Chain Width (mm)	Individual Element					Continuous Element			
			MG	MA	YG	YAN	VS	CF	EF	CH	FK
Ultra light	UL	2.5 - under 4.0						1CF 2CF			
Light	L	4.0 - under 5.5	3MG 4MG	3,4MA 5RA	3YG 4YG	3YAN 4YAN	3VS 4VS	3CF 45CF	3EF 4EF	2CH 3CH	25FK
Medium	M	5.5 - under 7.0	5RG 7MG	7MA	5YG	5YAN	5VS 75VSFF	5CNF	5EF		
Medium-heavy	MH	7.0 - under 8.5		8MA		8YAN	8VS 95VSFF	8CF			
Heavy	H	8.5 - under 12.0	10MG	10MA			10VF	10CF			
Ultra heavy	UH	12.0					15VF				

### Strength Requirement according to JIS Standard

Unit : N

Strength	Chain Crosswise		Top Stop Holding		Bottom Stop Holding		Separating Unit Crosswise	Retaining Pull-off	Slider Locking		Slider Mouth & Pull Holding (90°)	Slider Pull-tab Twist	
	Individual Element	Continuous Element	Metal Slider	Plastic Slider	Metal Slider	Plastic Slider			Metal Slider	Plastic Slider			
Zipper Typers	Tape with Reinforcement (for garment requiring higher durability)	Non-Cotton or Non-Knit Tape Aluminum Elements or Cotton or Knit Tape	Non-Cotton or Non-Knit Tape Cotton or Knit Tape		Individual Elements (Aluminum Elements, Cotton or Knit Tape) Continuous Element	Individual Elements Continuous Element	Individual Elements Continuous Element		Individual Elements Continuous Element	Individual Elements Continuous Element	Metal Slider Plastic Slider	Metal Slider Plastic Slider	
UL	300	150 / 100	200 / 150	40	30	15 / 30	15 / 20	50 / -	40	15 / 10	10 / 10	60 / 40	15 / 10
L	400	230 / 150	250 / 200	50	40	40 (30) / 50	30 / 30	70 / 50	50	25 / 10	20 / 10	80 / 50	15 / 10
M	500	300 / 200	450 / 200	70	60	50 / 70	40 / 60	80 / 80	60	40 / 35	25 / 25	150 / 100	45 / 35
MH	600	390 / 250	540 / 300	100	80	80 / 120	60 / 90	120 / 120	80	50 / 50	35 / 35	170 / 100	70 / 45
H	700	490 / 300	590 / 350	120	100	100 / 150	100 / 120	150 / 150	120	60 / 60	50 / 50	200 / 150	70 / 60
UH	800	690 / -	- / -	200	170	150 / -	150 / -	300 / -	200	- / -	- / -	300 / 300	- / -

Tensile Testing Machine Conditions — Tensile Speed: 300mm/min (for Slider Mouth & Pull Holding: 100mm/min), Clamp Width: 25mm. Reciprocating Endurance Testing Cycle: 500 Cycles for All Sizes



Recently, with diversification of materials and finishing processes, complaints have been voiced in various fields that the metal parts of copper alloy zippers (golden brass, yellow brass, and nickel silver) can change color or contaminate adjacent cloth.

## 1. When metals change color

Copper alloys generally react with such chemicals as acids, alkalis, oxidizing agents, reducing agents and sulphides often forming colored salts. When these chemicals are abundant in adjacent materials, a color change can take place on metal parts, such as elements, sliders and top and bottom stops or open parts. These chemical reactions occur more readily in hot and humid conditions. For example, if products are pressed after the sewing process with a steam iron and wrapped straight away, or are packed in polyethylene bags for a long time, this kind of reaction is likely to happen. Reactive dyed cloth may discolor and sulfur dyed cloth may cause the copper alloy to discolor and stain.

### ■Woolen knit products

When metal zippers are attached to bleached woolen knit products, a color change can take place.

Generally, woolen products are bleached by the following methods:

- (1) Using an oxidizing bleach (hydrogen peroxide, etc.)
- (2) Using a reducing bleach (hydrosulphite, etc.)

Furthermore, some woolen products are treated with chlorine oxidizers for a shrink-resistant finish.

If sufficient washing or neutralization has not been made after treatment, especially with hydrosulfite or chlorinating agents, gas (chlorine gas or sulfur dioxide gas, etc.) can be generated. These hydrosulfite and chlorinating agents can also react directly on metal in humid conditions. For example, if woolen products are put into bags immediately after pressing and kept as they are, various chemicals and gases will cause a color change on the metal parts of copper alloy zippers. In such cases, observe the following precautions.

- \* Use completely washed and dried woolen cloth.
- \* Take sufficient time before wrapping, after the products are pressed.

### ■Leather products

A color change can be caused by residual tanning agents or acids used in the leather tanning process. Such tanning agents as sulfuric acid and other mineral acids, chrome compounds, tannic acid and aldehyde compounds are used. Since the main ingredient of leather is animal protein, leather cannot naturally or easily rid itself of those tanning chemicals, and a large quantity of chemicals can often remain. When such leather comes in contact with metal zippers, it can, over a period of time in humid conditions, cause a color change in zippers. In such cases,

- \* Use leather which has been sufficiently washed and neutralized after tanning.

## 2. When metal zippers contaminate cloth of garments or other products, which are given some kind of finish.

### ■When GKB or GK golden brass zippers are used

When acid substances or oxidizing agents remain in the cloth used for products after dyeing or finishing, they can cause chemical changes on GKB or GK metal fasteners and can stain the portion where the zippers are in contact with white or light-colored cloth, especially. Also the zippers are likely to cause chemical reactions with reactive dyestuff. In such cases,

- \* Use material and cloth which has been sufficiently washed and dried after treatment.

### ■Transfer of paraffin to fabric, which has waterproof or water-repellent treatment.

Paraffin is coated on metal zipper elements to make them work smoothly. When metal zippers are attached to cloth which has waterproof or water-repellent treatment, the paraffin can melt during pressing, and transfer to the cloth causing staining. In such cases,

- \* Press with an iron after inserting several sheets of paper or cloth between the zipper and the material.

### ■Discoloration and color change of cotton products dyed with reactive dyestuff.

Reactive dyestuff used for over-dyeing cotton products contains metal ions.

Discoloration or a color change may occur in humid conditions when the dyestuff reacts with copper alloys used for metal fasteners.

- \* In case of over-dyeing, dry sufficiently and keep the products in a dry place.
- \* Avoid sealing the garments in plastic or vinyl bags.
- \* Avoid warm and humid environments when storing or displaying your garments.

YKK is conducting research and development for protection against these various conditions. However, at present, we must rely on users cooperation in such special cases, so we must inform you of these facts and ask you to observe the above-mentioned precautions.

When it is suspected that corrosion resistance of metal zippers may not be sufficient under special conditions, the use of YKK Vislon® zippers or coil zippers is recommended.

# Zipper Problems and Solutions (Q&A)



●If you have any questions upon the use of zippers, please contact YKK representatives or visit our website at : [www.ykkfastening.com/](http://www.ykkfastening.com/)

## Selection of Zippers according to Applied Materials or Usage

- Q** The No. 3 zipper was used for thick fabric over 12 oz. caused the pull-tab and zipper chain breakage.
- A** ●Please use No. 4 or larger items for thick fabric. No. 3 items can be used for light fabric only.
- Q** Pin-lock type (DP) slider used at the pocket may hurt users.
- A** ●Please avoid using DP type and use DA (automatic-lock) type or DF (free-lock) type slider instead.

## Garment Wash Process

- Q** After the garment wash process, the applied zipper was tarnished or corroded. Also the tape became weak and easily torn..
- A** ●Please use YG items (No. 3 – 5) that are more resistant to wash process.  
●Rinse thoroughly to ensure chemicals do not remain on the zipper after washing and dry completely.  
●Conduct the preliminary testing as the various chemicals or washing processes can cause various effects.
- Q** A slider broke when the DA type was used for an article given washing treatment.
- A** ●The pull-tab of DA slider can get caught in the tumbler and damaged, or the treatment chemical may stay in the slider cover and cause corrosion problems.  
●Please use GS (semi-automatic lock) type sliders that are better in both strength and structure.
- Q** After the bio wash process, zipper defects were found.
- A** ●Please conduct the preliminary testing as chemicals used for the treatment may cause unexpected effects.

## Migration (Dye Transfer)

- Q** Migration of the dye occurred when the zipper is applied to certain types of fabrics.
- A** ●Migration of the dye may occur when the zipper is in the contact with agents contained in PVC, synthetic leather or plastic coating of the fabric. Insert a sheet of paper between the zipper and the garment fabric. Also avoid storing in piled condition.

## Tarnish / Discoloration

- Q** Metal zipper elements (copper-alloy) became black and discolored or stained the fabric
- A** ●It is copper's nature to turn blackish when oxidized. Please store in a well-ventilated environment and avoid storing in humid conditions. Excella® or Ever Bright® items which have higher resistance to tarnishing are recommended.
- Q** After storing zippers with rubber band bundling, the bundled part of the zippers discolored.
- A** ●Please avoid bundling with rubber band for prolonged storage.

## Staining

- Q** A metal zipper stained the adjacent garment fabric.
- A** ●If the garment fabric or other materials are treated with chemicals or dyes, the residual chemical may react with the metal element and stain the fabric. Ensure to thoroughly wash and dry the treated fabric before sewing the zipper.
- Q** Garment fabric was stained by melted Paraffin after ironing.
- A** ●Paraffin wax is applied onto the zipper elements for smooth operation. Please place a sheet of cloth between the zipper and the garment fabric when ironing.

### Anti-Nickel

**Q** A zipper made of or coated with nickel caused an allergic reaction on direct contact with the skin.

**A** ● Please select aluminum products and/or specify the anti-nickel specification if the silver-colored zipper is required.

### Permanent-Press Treatment

**Q** When such permanent-shape treatment as VP treatment was applied, the zipper tarnished or corroded.

**A** ● Please select the items that are resistant to those treatments. Conduct the preliminary testing before applying SSP or Double Action treatments as well as VP treatment.

### Sewing

**Q** The sewing needle stung the top stop and the protruded edge caused by the needle injured the skin.

**A** ● When sewing, do not insert a needle into the top/bottom stops of a zipper

**Q** When opening or closing a zipper, the slider caught the fabric.

**A** ● Please leave enough room for the slider to move smoothly when sewing the zipper onto the fabric.

**Q** At the lock stitching, the weft of the zipper tape was cut therefore the tape yarn came apart.

**A** ● Please be aware that the zipper tape is a woven fabric. Cutting of the weft would result in raveling of the yarn.

### Others

**Q** Precautions on applying zippers on baby garments.

**A** ● Special products for baby garments, such as plastic stops, are available. Please contact YKK representatives for detail.

**Q** The slider caught the fabric and damaged the fabric, or the slider got stuck.

**A** ● Pull back the slider slowly and then move the fabric. Do not exert excessive force to move it or the pull-tab may be broken.

**Q** After the dry-cleaning, the slider was broken from the iron pressing.

**A** ● Do not iron on or close to the sliders.

**Q** The zipper element got melted during ironing.

**A** ● Please make sure to place the ironing cloth over the zipper:  
○ Vislon® = 130°C  
○ FlatKnit® = 150°C  
○ Conceal®, Coiled Zipper = 160°C

# Proper Use of Zippers



※Please see “Structure of Zippers (P.3)” for the name of each zipper part.

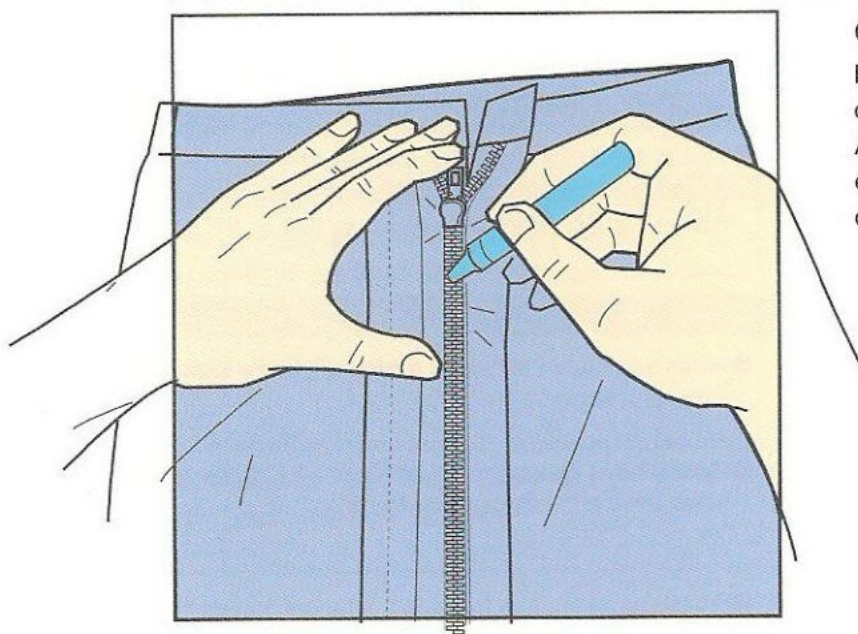

## ●Unsmooth Slider Operation

Do not force to move the slider even if it doesn't move smoothly or it may cause the element misengagement. Apply paraffin or wax on both front and back surfaces of the element then move the slider back and forth to regain the smooth operation.

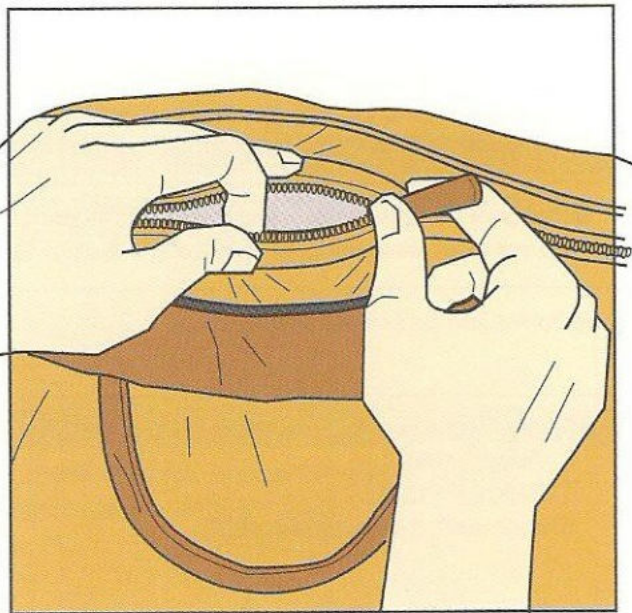

## ●Pulled Out Element

Trying to forcibly close the zipper of an overfilled bag, which will cause the element slip off or tape breakage due to the excess load on the elements. Reduce the burden by removing the bag content and by bringing both sides of the chain very close to each other before closing the zipper.

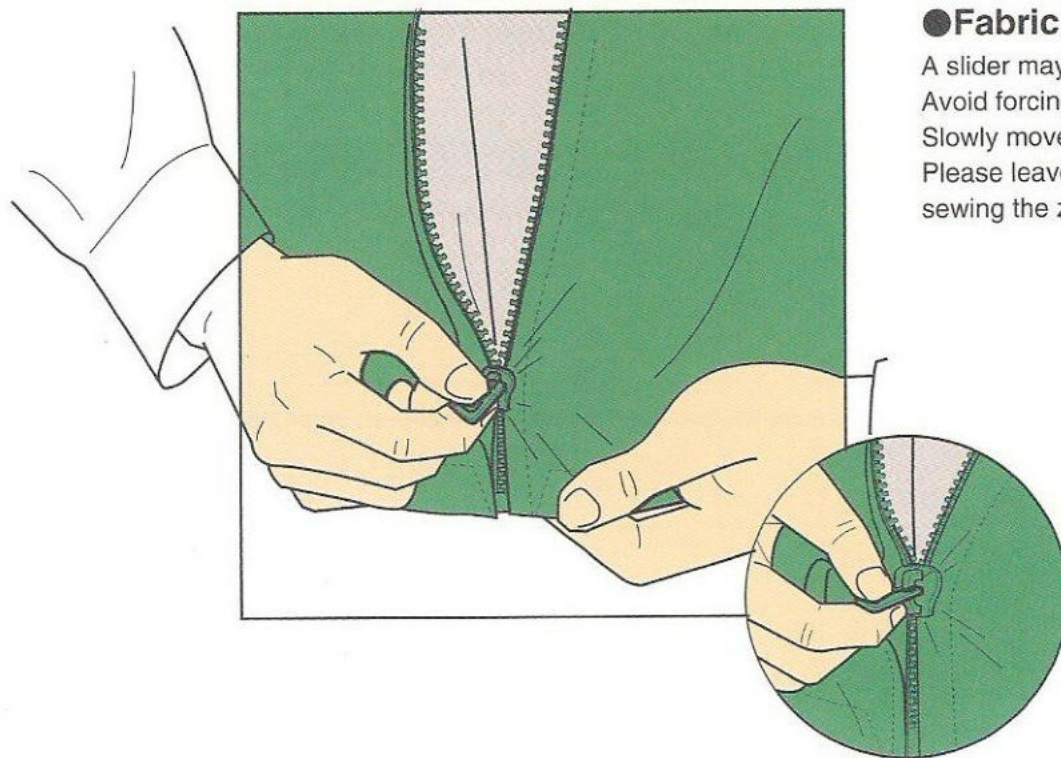

## ●Fabric Caught in Slider

A slider may catch the fabric and get stuck during its operation. Avoid forcing it to move or it will worsen the problem. Slowly move the slider while pulling out the caught fabric. Please leave enough room for the slider to move smoothly when sewing the zipper onto the fabric.



### ●When Dressing / Undressing Garments

Make sure to completely open the zipper when dressing/undressing the clothes. Dressing/undressing with incomplete zipper opening, may damage elements / slider function.

When closing the zipper, the slider will move smoothly if the hook & eye or the top button is fastened beforehand.

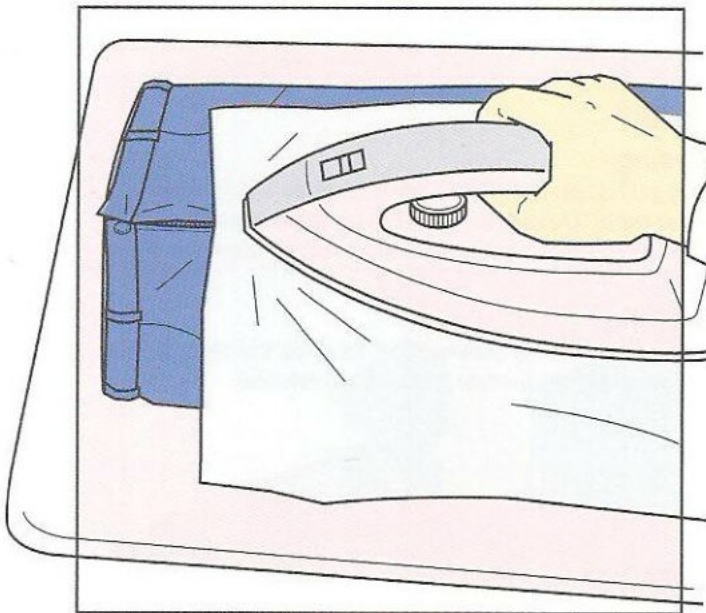

### ●Proper Ironing Procedures

Not only the garment fabrics but also zippers have appropriate ironing temperature according to their materials. Please keep the specified ironing temperature to maintain the zipper quality. Also make sure to completely close the zipper, lay down the slider pull-tab in the regular position and place ironing cloth on the zipper.

#### Maximum ironing temperature

CONCEAL®	160°C	(Pressure: 1.5kg, Applied for 10 sec.)
FLATKNIT®	150°C	※Direct ironing onto elements or sliders may cause undesirable effects.
VISLON®	130°C	
Coil Zippers	160°C	

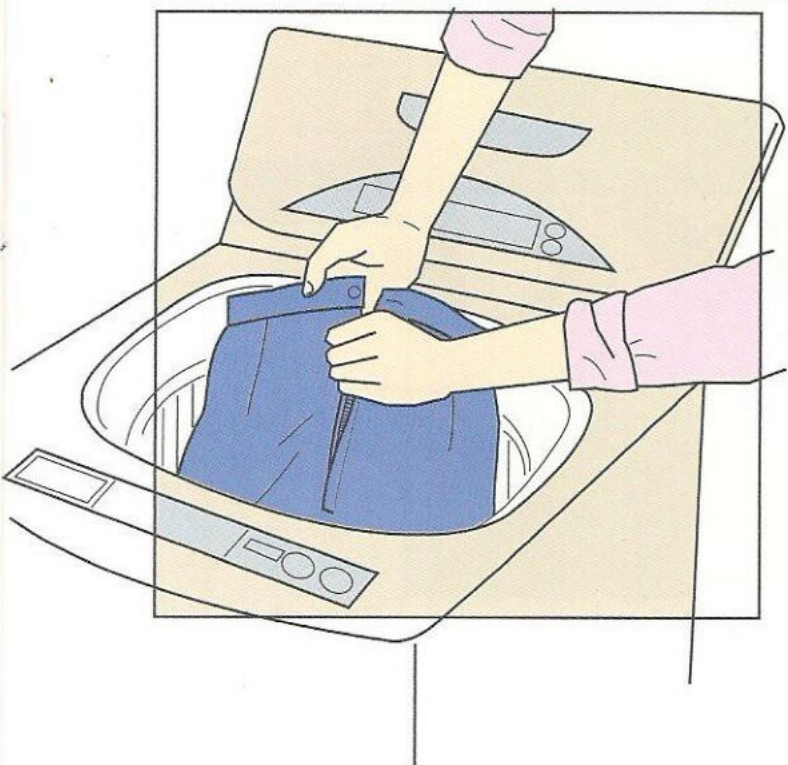

### ●Proper Laundry Procedure

Make sure to completely close all the zippers when using the washing / dryer machines. Incompletely closed zipper may be entangled with other load and result in element or slider damage or damage on other fabric.

Long or slim slider pull-tab may be caught in the drum holes and broken so the use of the laundry net for those items is recommended. After the dryer process, do not operate the zipper until the garment temperature cool down to normal.

Strong alkaline detergent or chlorinated bleach may affect the zipper operation. In that case, use softeners, paraffin or wax to regain the smoothness.

Do not presoak garment with zippers in washing solution or it may give a significant damage.

# Proper Use of Open-End Zippers



※Please see "Structure of Zippers (P.3)" for the name of each zipper part.

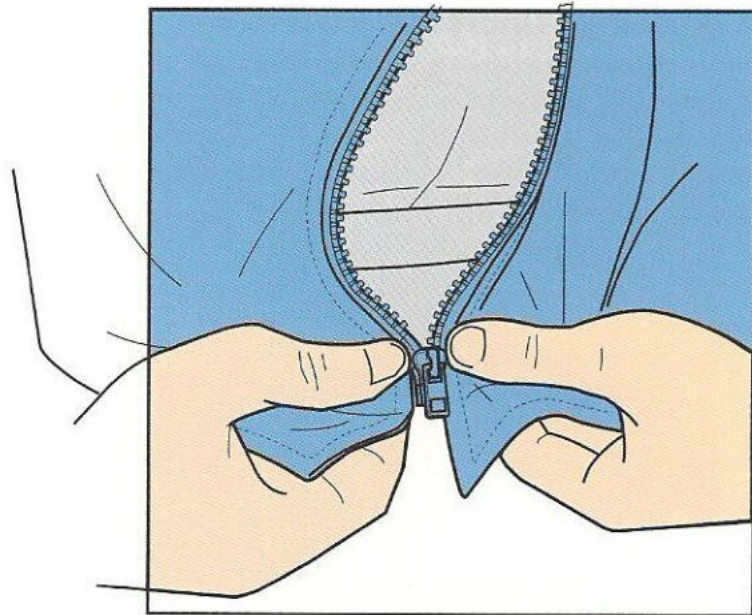

Instructions for right hand insertion zippers.

## ●Open-end Zipper

### ■When closing

1. Completely pull down the slider until it touches the retaining box.
2. Insert the insert pin to the very bottom of the box.  
(Incomplete insertion may cause troubles.)
3. Holding the insert pin side with the right hand pull up the slider with the left hand.

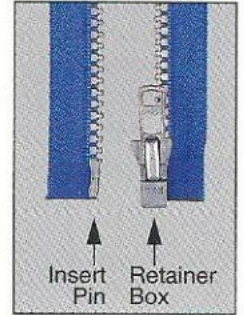

### ■When opening

1. Completely pull down the slider until it touches the retainer box.
2. Gently pull out the insert pin with the right hand

<Structure>

Insert Pin Retainer Box

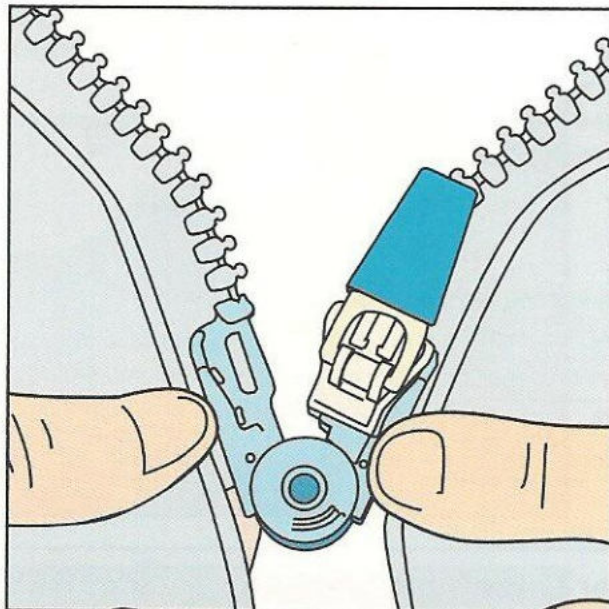
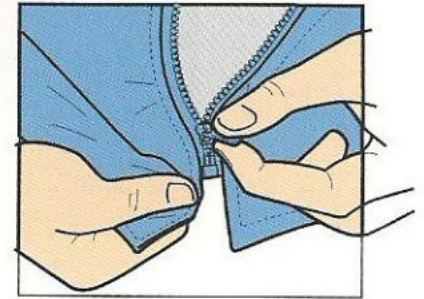

Instructions for right hand insertion zippers.

## ●SnapTrak®

### ■When closing

1. Completely pull down the slider until it touches the retainer box.
2. Snap on the parts. (Angle: 0 – 45°, Lift up slider pull-tab.)
3. Rotate the snap to close both ends then pull up the slider.

### ■When opening

1. Completely pull down the slider until it touches the retainer box.
2. Open up both sides and rotate the snap to release.

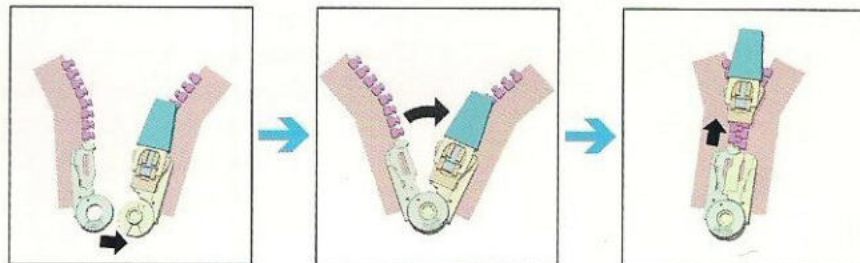

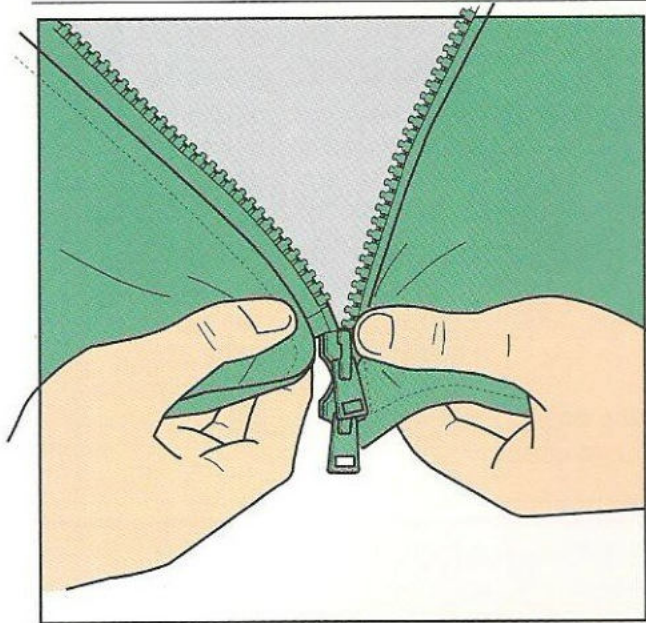

Instructions for right hand insertion zippers.

## ●Two-way Open

### ■When closing

1. Pull down the upper slider until it touches the bottom slider.
2. Insert the insert pin to the very bottom of the bottom slider.  
(Incomplete insertion may cause troubles.)
3. Pull up the upper slider with the left hand.

### ■When opening

1. Completely pull down the slider until it touches the bottom slider.
2. Gently pull out the insert pin with the right hand

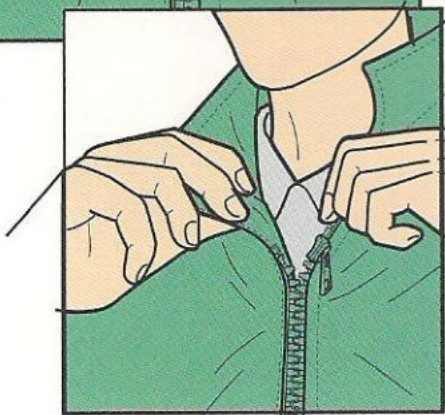
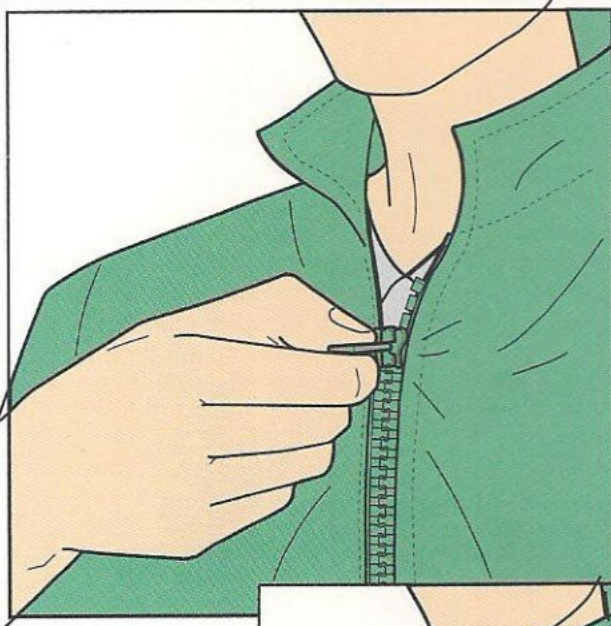
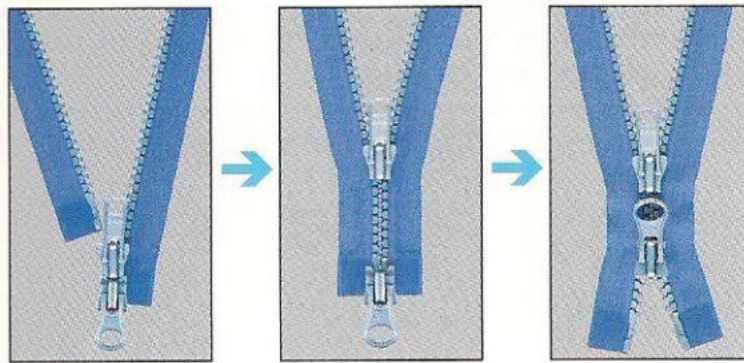

## ●Top-open Zipper

### ■When closing

1. Pull down the slider until it touches the retainer box.
2. Insert the insert pin to the very bottom of the box.  
(Incomplete insertion may cause troubles.)
3. Pull up the slider.

### ■When opening

- If the slider is forced up further than the position shown in Figure A, the zipper will open from the top as shown in Figure B.
- This zipper can also be opened as the regular open-end zippers.

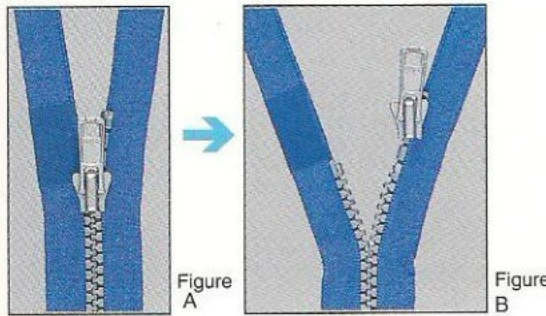

Metal top-open zipper



# Sewing "CONCEAL"® Zipper onto Fabric



Prepare a zipper approx. 2 cm longer than the actual garment opening.

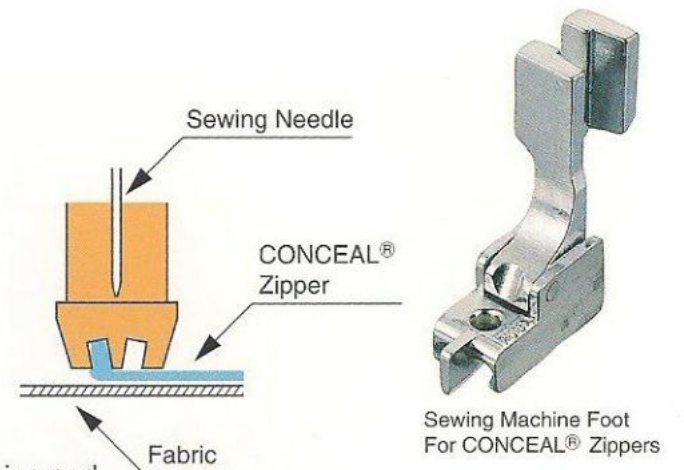
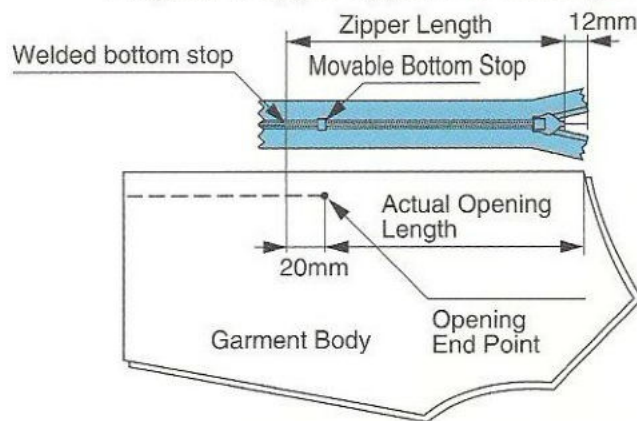

## Movable Bottom Stop

Movable bottom stop is provided to prevent fraying of the fabric at the opening end. Fraying by the slider movement can be prevented by fixing the stop about 5 mm upper than the opening end point with the special jig.

## When the opening end is already sewed

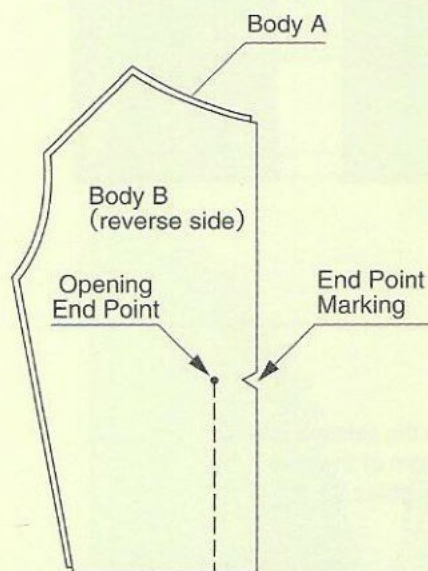

- 1) Place Body A and B together and sew to the opening end point.
- 2) Make sure to backstitch at the end point.
- 3) Mark the end point on the fabrics.

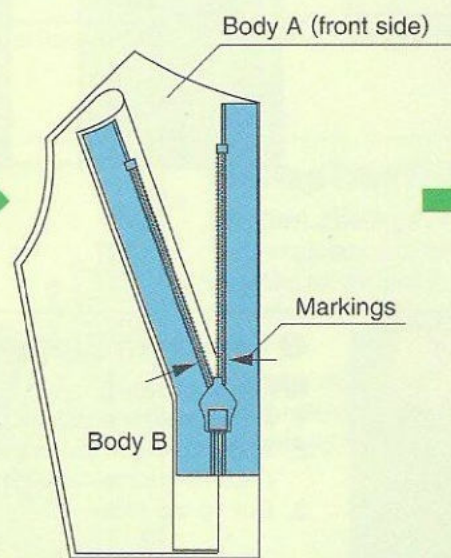

- 1) Put together the body fabrics and the zipper then mark the end point on the zipper.

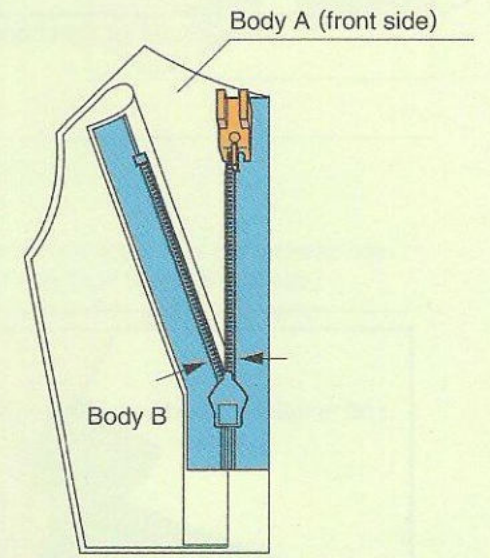

- 1) Pull down the slider to the bottom stop then sew on both sides of the zipper, making sure both markings are met.
- 2) Use YKK sewing machine foot, raising the element up and fitting in the groove of the foot.

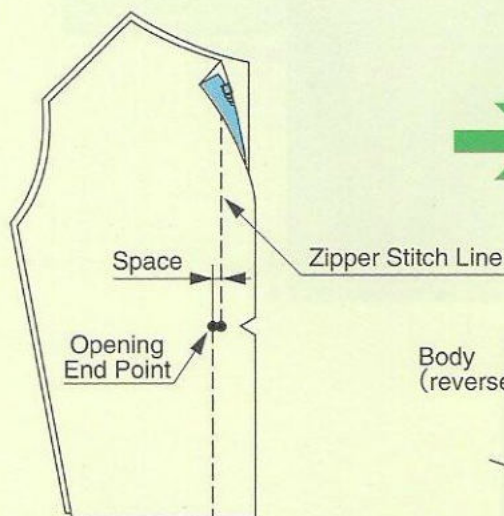

- 1) Sew on the zipper to the opening end point.
- 2) Backstitch at the beginning and the end of the stitch.

※ Do not overlap the zipper stitch lines with the body stitch line; leave room for the slider pull-tab to pass through.

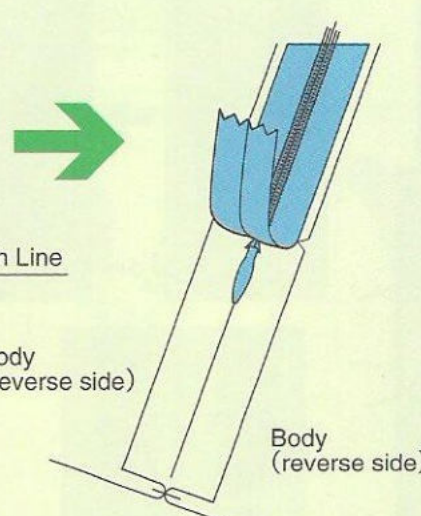

- 1) Bring the slider pull-tab out to the front side then close the zipper.

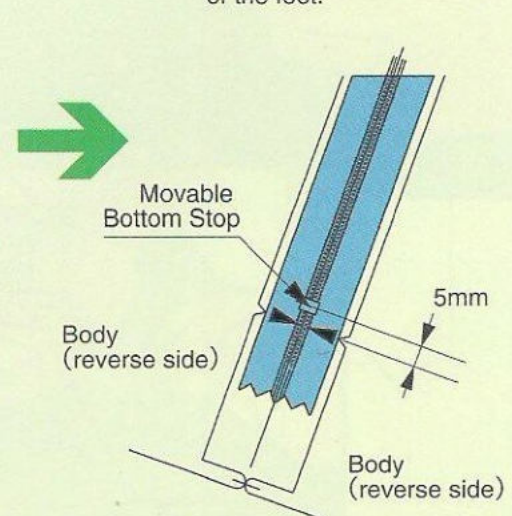

- 1) Position the movable bottom stop about 5 mm above the opening end point then fix using the special jig.
- 2) The stop prevents fraying of the fabric at the opening end.

## ■ Proper Sewing Procedure of Zippers

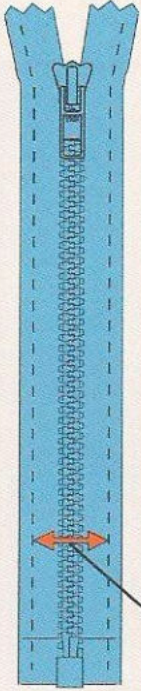

### ● Space for Slider

For zipper operation, some space for slider movement needs to be reserved. If the stitch is made at the very side of the element, sliders easily catch the adjacent fabric. Please make sure to leave enough space for the slider operation. Lining cloth especially gets easily caught in the sliders, so sew on the part away from the element and secure the edges with sewing machine or prick stitch if the lining is used.

### ● Sewing Long Zipper

Considering the compatibility between the fabric and the zipper, tack the zipper before actually sewing on the fabric and check their elongation and so on.

Knit fabric especially requires this preliminary check.

### ● Sewing onto Shaggy Fabric (Fur, Shaggy, etc.)

When applying zipper onto shaggy fabric, place cover cloth, such as leather or other measures at the edges in order to prevent the slider from catching the fabric.

Leave enough space for slider operation.

## ■ Sewing Zipper on Bottom Flies

Saddle stitch can reduce the burden to the bottom stop. Garments using a short zipper or tight-fitting garments especially give great burden to the stop so applying the saddle stitch is strongly recommended.

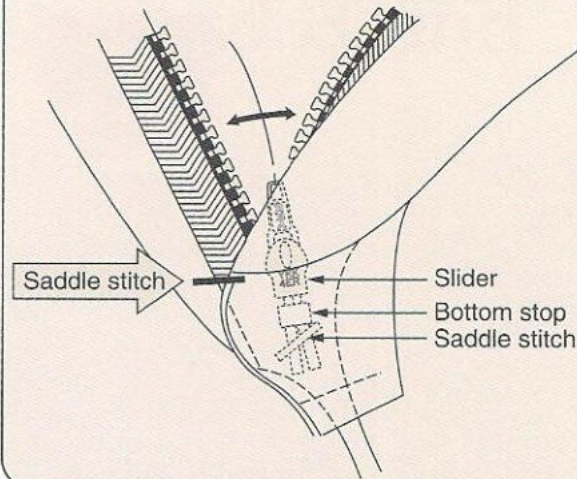

## When sewing the opening end after attaching the zipper to the bodies

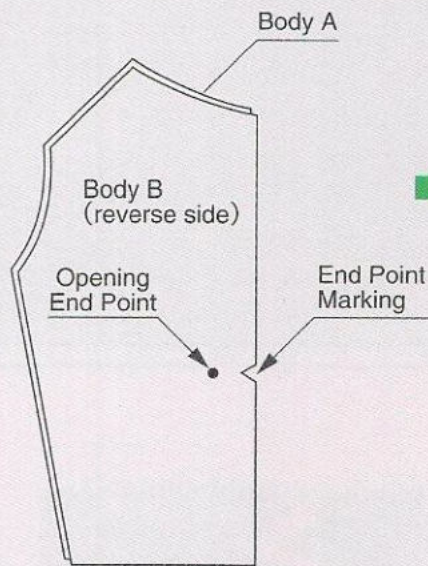

- 1) Mark the end point of the opening on the fabrics.

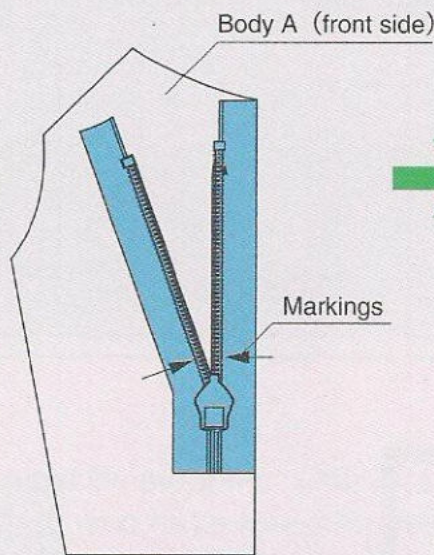

- 1) Put together the body fabrics and the zipper then mark the end point on the zipper.

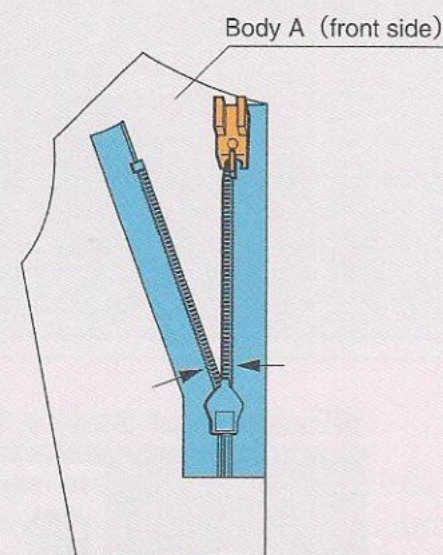

- 1) Pull down the slider to the bottom stop then sew on both sides of the zipper, making sure both markings are met.
- 2) Use YKK sewing machine foot, raising the element up and fitting in the groove of the foot.
- 3) Backstitch at the beginning and the end of the stitch.

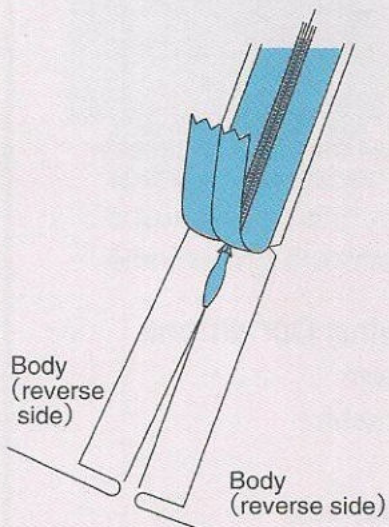

- 1) After sewing both sides of the zipper, close the zipper ensuring the pull-tab comes on the body front side.

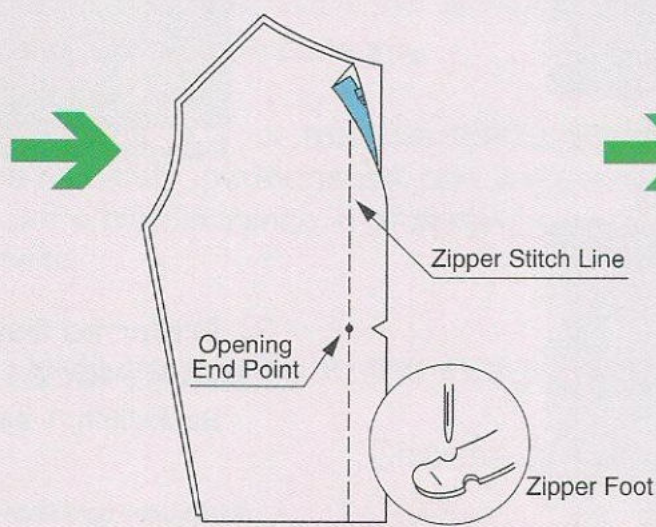

- 1) Sew together both bodies using the ordinary zipper foot below the opening end point. Backstitch at the beginning and the end of the stitch.
- 2) Both stitch lines (above & below the end point) should be aligned straight.

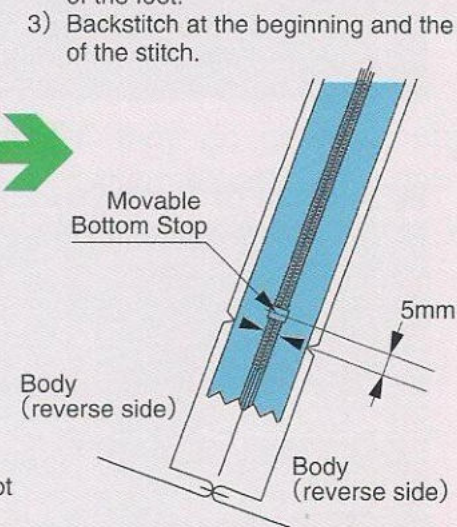

- 1) Position the movable bottom stop about 5 mm above the end point then fix using the special jig.
- 2) The stop prevents fraying of the fabric at the opening end.



Switch to the ordinary zipper foot here as the insert pin has got protrusion.

Pull up slider and retainer box.

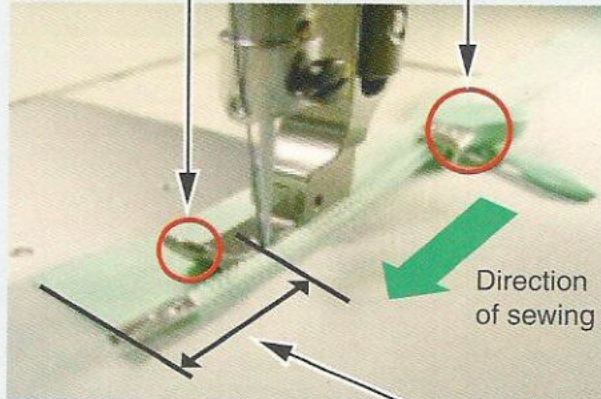

Approx. 25mm

- 1) Sewing on Retaining Box Side  
Start sewing from the top of the zipper. Pull up the slider and the retainer box at approx. 25 mm from the bottom end then sew on the part right beside the element edge.

※For No. 3 CONCEAL® zipper, the retainer box can move for better appearance after sewing

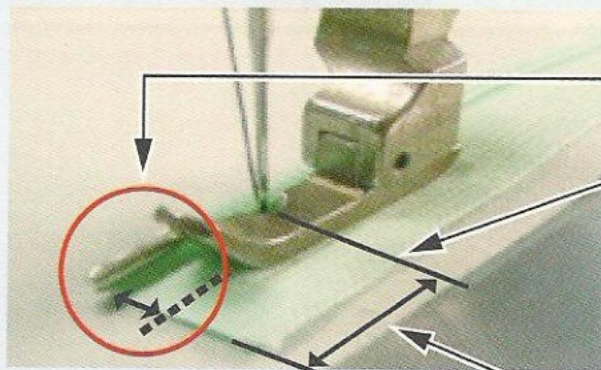

Approx. 10mm

- 2) Sewing on Separable-Pin Side  
Sew on the part right beside the element edge until the point approx. 10 mm from the bottom end. Move slightly (approx. 1 mm) away from the insert pin then continue sewing to the bottom end.

※Sewing on the very edge of the insert pin may cause insertion problem of the pin to the slider.

■ Example of Sewing Error

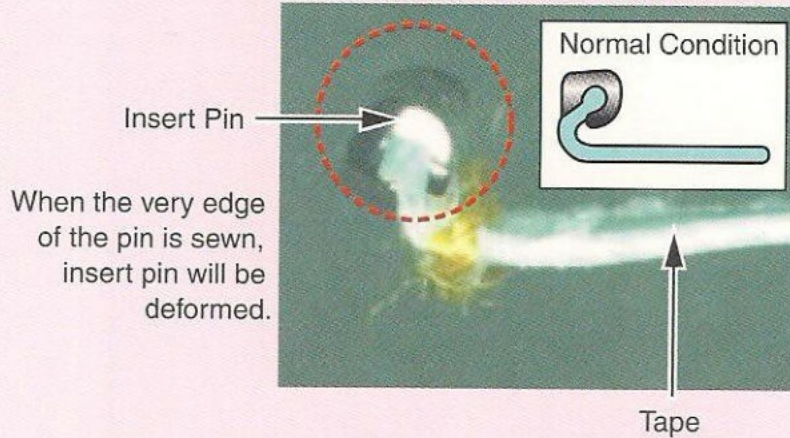

When inserting to the slider



Deformed pin causes the insertion problem

■ Example of Poor Sewing

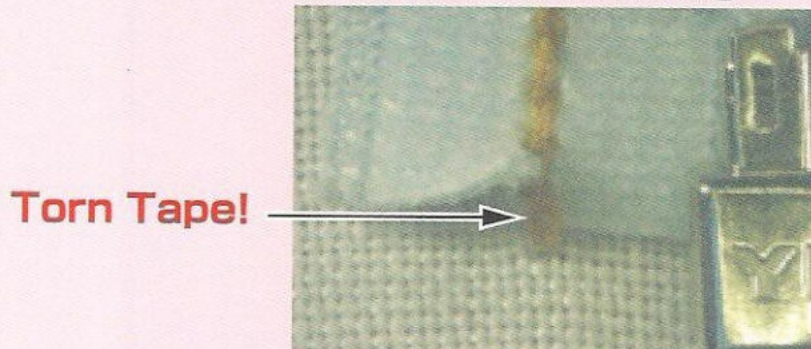

Too small sewing pitch and repeated backstitches will cause the tape breakage.

- 3) Preferred Sewing Conditions  
Sewing Pitch: 2.5 mm  
Backstitch: 1 backstitch

※Repeated backstitch may result in the zipper tape breakage



## Protect Your Product and Brand



Counterfeiting is a crime that must be stopped. One of the biggest concerns for intellectual property owners, counterfeiting betrays consumers who have relied on the integrity of a trusted brand by purchasing it. When it fails, its quality cannot be guaranteed. While counterfeiters steal a free ride on the hard-earned reputation of an established brand, they also deceive consumers and betray their confidence.

YKK believes strongly that enhancement of our intellectual property ties directly to reducing and eventually eliminating all counterfeit activities. We know eliminating counterfeits will also benefit our valued customers and all consumers who rely on brand integrity.

Zipper may be little parts in your manufactured product, but they do have an important function that sometimes enhance its safety, performance, and endurance. Working together, we can win the fight against counterfeits and make a big difference in protecting your brand. It is our goal to assist you in identifying and eliminating counterfeits.

Help yourself and the integrity of your product and brand :

Choose genuine YKK

**[YKK®]** is a registered trademark of YKK corporation, which is protected in 171 countries over the world.

# BALL CHAIN



## Metal Ball Chain

YKK's ball chains are made of brass, stainless steel, and aluminum. Because of their functional and fashionable characteristics, ball chains are used in a variety of fields. A variety of ball chain finishes are available.

Brass (Br.) /Stainless (St.) /Aluminum (Al.) BALL CHAIN	Size Ball diameter (mm)	Material
	1.5	Br.
	2.0	Br.
	2.3	Br.
	2.3	St.
	2.5	Br.
	3.0	Br.Al.
	3.2	Br.St.
	3.5	Br.
	4.0	Br.
	4.5	Br.
	4.5	St.
	5.0	Br.
	7.0	Br. St.
Ball bar Chain		3.0 Br.
Bead Chain		3.0 Br.

Powder coating is available for Metal Ball Chain. Please contact YKK sales representatives when ordering.

Powder Coating	Sample	Size	Material

## Attachments

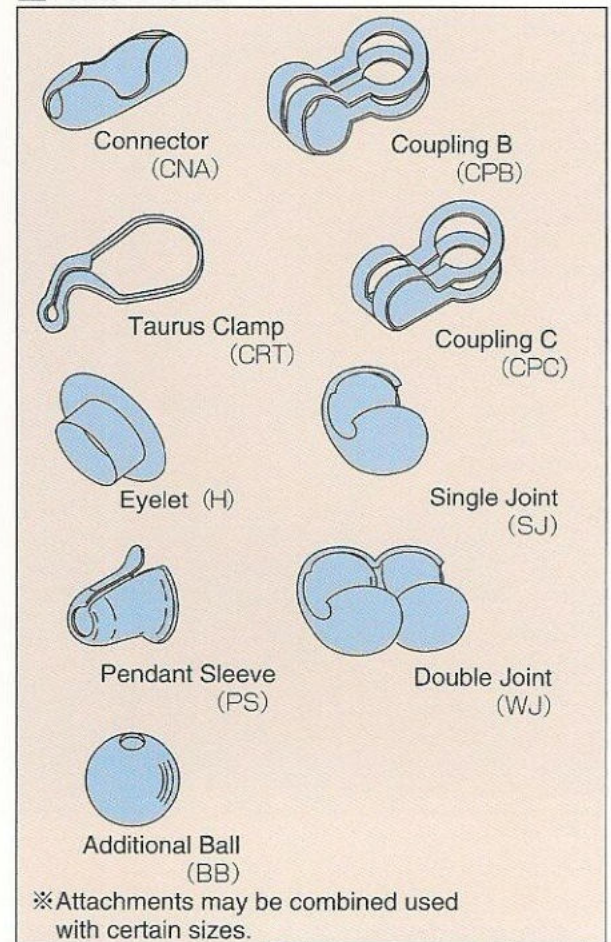

## Name of each part of the ball chain

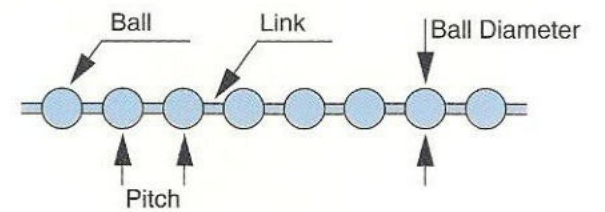

## Plastic BALL CHAIN

Standard Colors	No.
	055
	501
	504
	519
	540
	560
	568
	580
	80C1
	80C2
	80C3
	80C4
	80C5

### ■ Features of color balls

- Plastic balls are attached to a nylon or polyester string, which is flexible, bends freely, and soft to the touch.
  - Colors are standard and bright fluorescent. A two-tone color ball is also available with string and balls of different colors.
  - Easily cut to the required length.
  - Easily connected by a connector.  
(Can be welded utilizing the properties of plastic.)
- ※ Special order products with various ball lengths, shapes, and pitches are also available.

### ■ Attachments

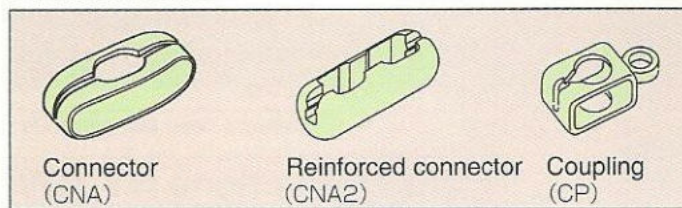

### ■ Types and dimensions

measurement : mm

	D (Outer diameter)	L (length)	P (pitch)	Cord Material	Plastic Ball
<b>35BR</b>	3.5	4.5	8.8	Nylon	Polyacetal
<b>48BR</b>	4.8	6.2	12.0	Polyester	Polyacetal
<b>58BR</b>	5.8	7.0	13.5	Nylon	Polyacetal

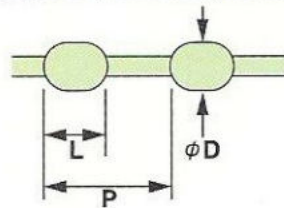

Size	No.
	35BR
	48BR
	58BR

Glow in the dark "LUMIFINE®"	
	M1 (White)
	M2 (Green)
	M3 (Yellow)
	M4 (Blue)
	M5 (Pink)

● Code : 35BRK      ● Cord color No. :  
 48BRKT      #01M1 (WHITE)  
 58BRK      #80M1 (BLACK)

Glow in the dark

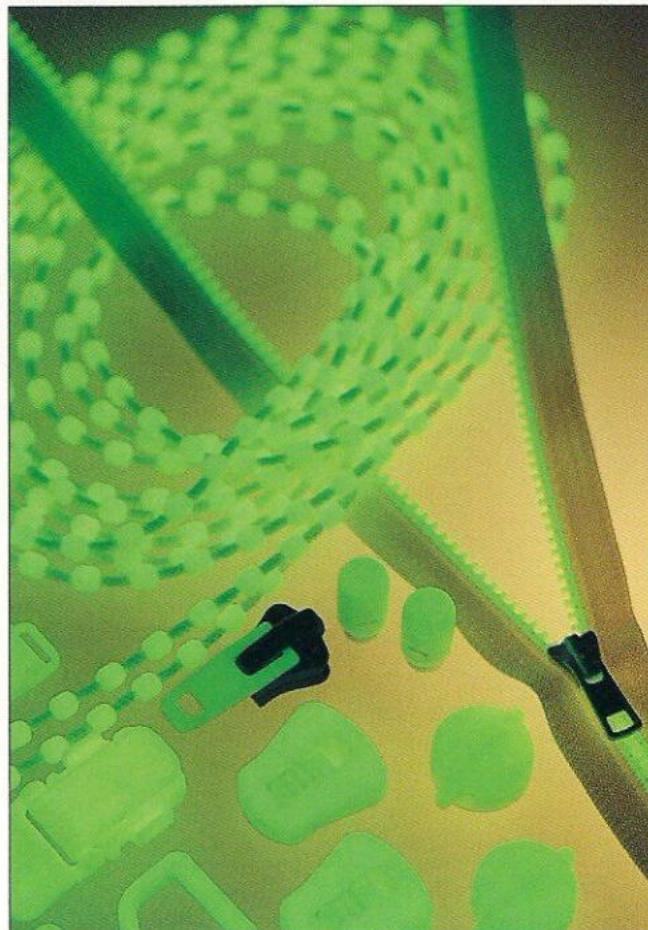

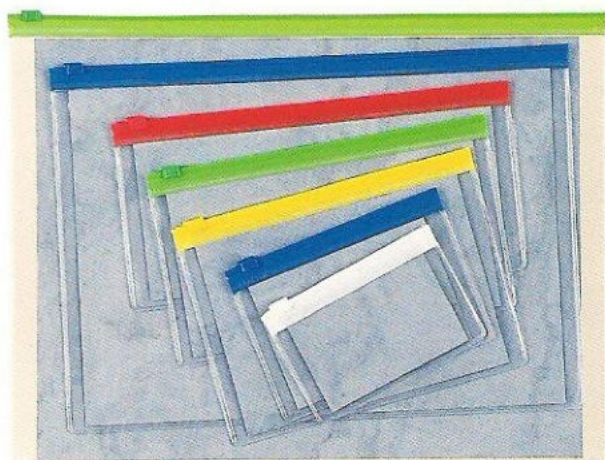

We offer various JOYLON® items for usage ranging from stationery and fancy goods, to industrial materials.

The JOYLON® products come in a wide variety of colors, types, and sizes. Please select the item appropriate for your use.

JOYLON® products: Six types of PVC products.  
Seven types of Olefin products.  
Seven Standard colors.  
Transparent and DTM are also available.

(Please contact YKK sales representatives when ordering.)

- Usage
  - Stationery such as large datebook, clear file.
  - Cosmetics, tooth brush, towel cases etc.
  - Household goods and clothes cases.
  - Computer cable connector, and battery case for cellular phones.
  - Tool box.
  - Document case etc. (various sizes)

### Care Instructions for JOYLON®

- There is a possibility of expansion and contraction by a sudden change of temperature.
- A color change may occur if stored for a long time in hot and humid conditions.
- Avoid use on curved application.
- Avoid use on excessively long part or where certain strength is required.
- Keep closed after attaching JOYLON® for shipping.
- Avoid use in an extremely cold (especially those made of vinyl chloride) and hot conditions.
- Conduct the adhesion test of the film in advance.
- If stored in a cold condition in winter, keep it at normal temperatures before use.

### 2EVVN · 2EVDN · 2EVTN · 2PVVN CH/ Care Instruction

- 2PEVN · 2PEDN · 2PETN · 2PVVN are easy to open from outer side but hard to open from the inner side.
- To help you check the direction of the chain. The "Round edge" is to help you check the correct direction of the chain. When attaching to the bag, make sure the "Round edge" is pointed to the outer side of the bag.

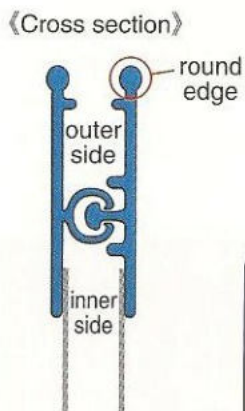

#### Standard Colors

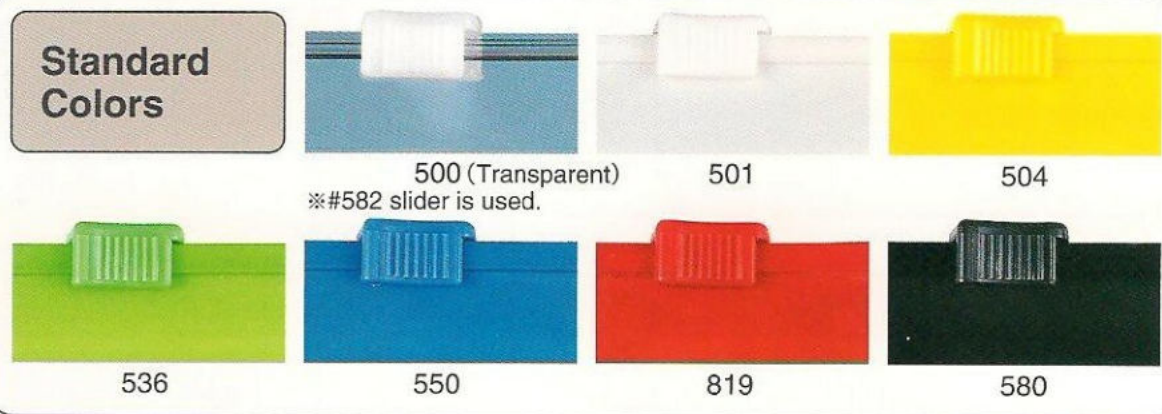

#### Transparent

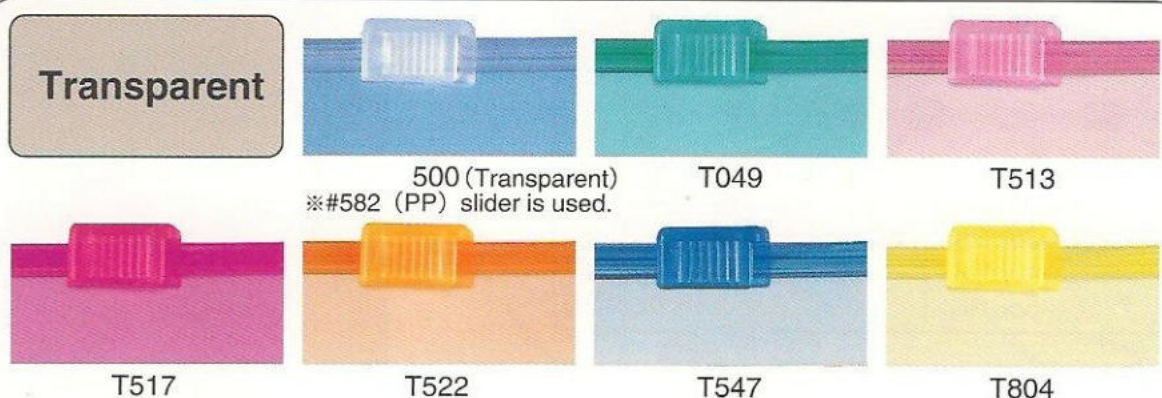

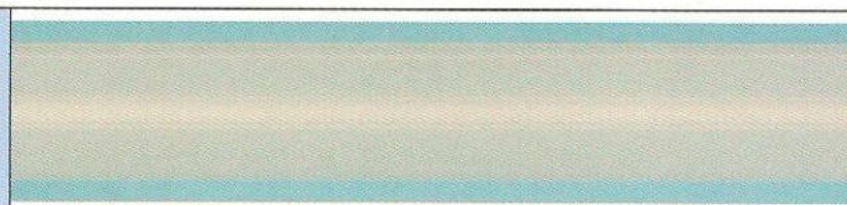
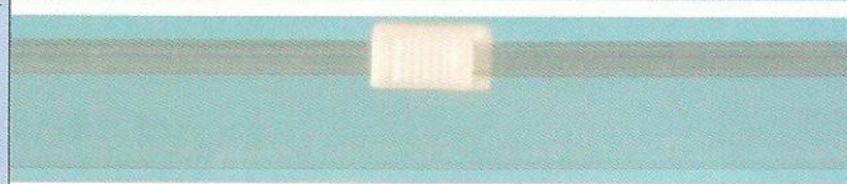
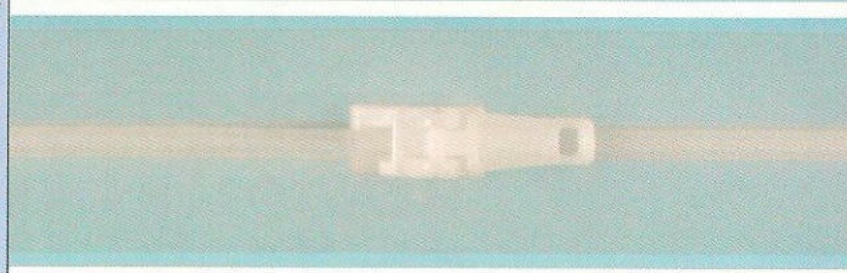
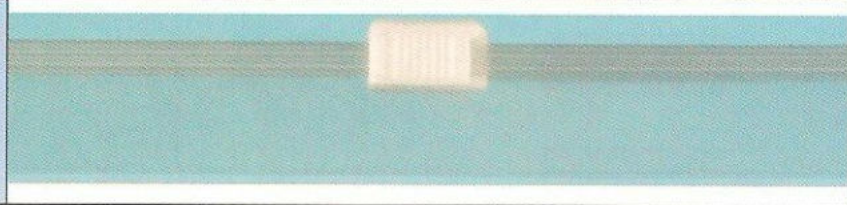

## ■ Olefin products

2EVVN		<ul style="list-style-type: none"> <li>● Can be high-frequency/ultrasonic processed or heat sealed on EVA film.</li> <li>● No slider necessary - open and close with fingers.</li> </ul>
3EVV3		<ul style="list-style-type: none"> <li>● Can be high-frequency/ultrasonic processed or heat sealed on EVA film.</li> </ul>
3EVH		<ul style="list-style-type: none"> <li>● Can be ultrasonic processed or heat sealed on PE film.</li> </ul>
3PPNL		<ul style="list-style-type: none"> <li>● Can be ultrasonic processed or heat sealed on PP film.</li> </ul>

※3PPH · 2EVDN · 2EVTN are also available.

## ■ PVC products

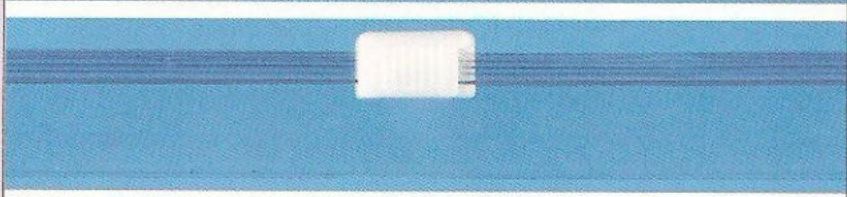
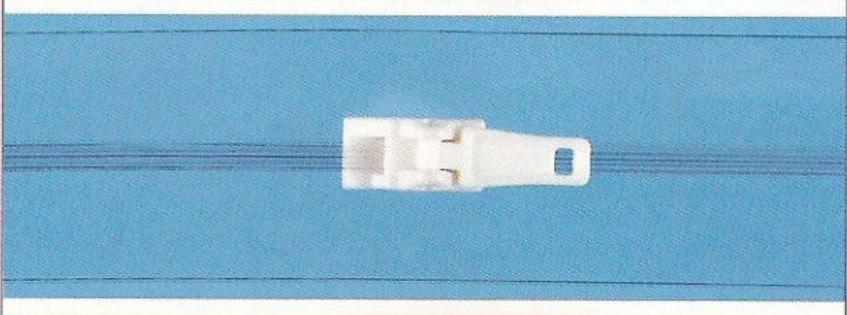
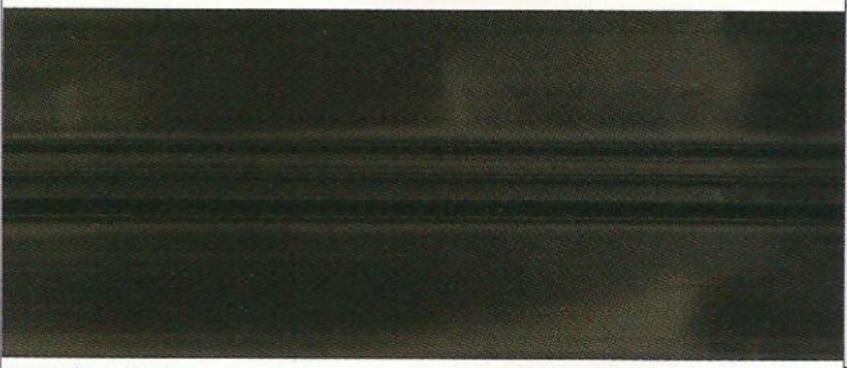
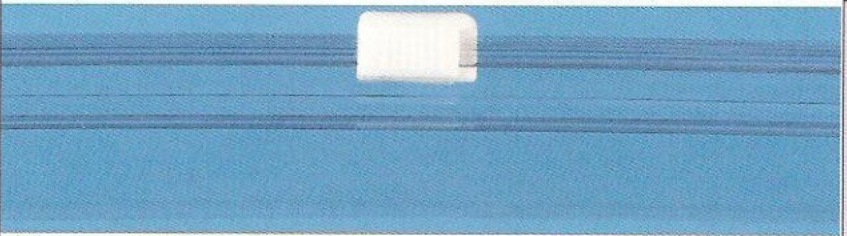
2PVVN		<ul style="list-style-type: none"> <li>● No slider necessary - open and close with fingers.</li> </ul>
2PVV		<ul style="list-style-type: none"> <li>● Small size. For fancy goods, caddies and datebooks.</li> </ul>
3PVV		<ul style="list-style-type: none"> <li>● The rail has no directions, two sliders can be passed from both sides.</li> </ul>
3PVH		<ul style="list-style-type: none"> <li>● Horizontal type for opening and closing flat faces.</li> </ul>
5PVH		<ul style="list-style-type: none"> <li>● Flat type in large size.</li> </ul>
23PVVS		<ul style="list-style-type: none"> <li>● Splash-proof</li> <li>● Made by combining 3PVV and 2PVVN (produced on order).</li> </ul>

The products depicted are actual size.

※5PVH is also available.



**Principle of cosmolon®**

Engagement of HOOK and LOOP.

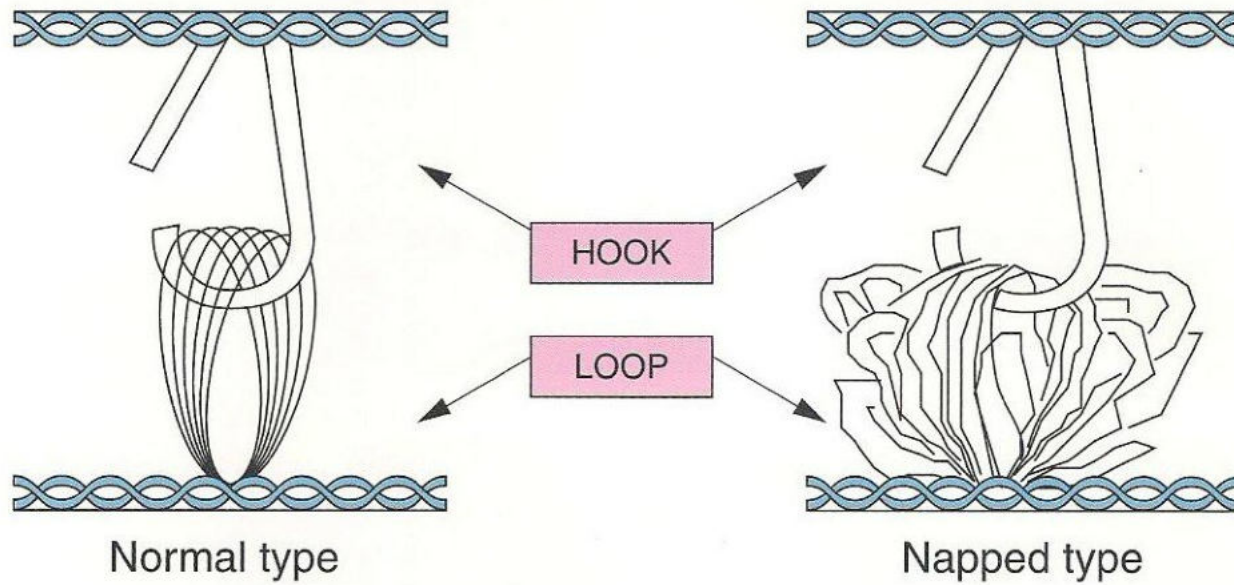

■ HOOK type

● Normal type

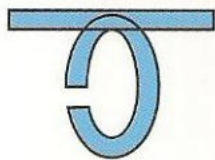

● Mushroom type

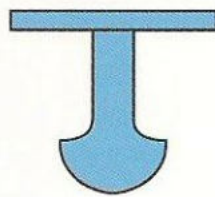

● Injection or Extruded type

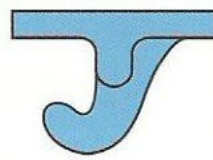

■ LOOP type

● Normal type

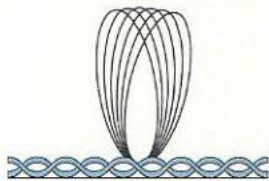

● Napped type

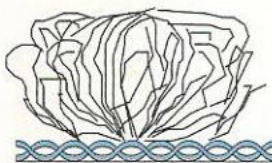

※ Choose the most appropriate combination of Hook and Loop recommended for your application.  
Please refer to page 44-45.

**SOFT**

**ELASTIC**

**Ultra Soft type**  
1QSK-N+2QKWC-N

**Soft Elastic Knit type**  
2QWE1-N(Loop tape only)

**Super Soft type**  
1QSAC-N+2QKWC-N

**Soft type**  
1QS-N+2QKWM-N

**Elastic type**  
1QNE-N+2QNE-N

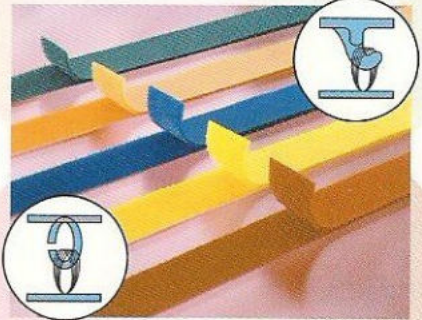

**Normal type**  
1QNN-N+2QN-N

**Strong type**  
1QF-N+2QM-N

**Soft + Napped type**  
1QS-N+2QM-N

**Mushroom type**  
1QP-M+2QKWM-N

**DURABILITY**

**EARLY STRENGTH**

others...

- Mixed Hook & Loop . . . . . 4QNN-N
- Back to Back . . . . . 5QN-N / 1QESA-L×2QKWC-N LAMIB-B
- WEBTOUCH® . . . . . 1QNNWT-N×2QNNWT-N

cosmolon® types and uses

		Kind	Material	Features	
cosmolon® (Hook and Loop Fastener)	Hook Tape (A)	Woven	NORMAL type 1QNN-N	<ul style="list-style-type: none"> <li>■ Fish hook-shaped pile for reliable engagement.</li> <li>■ Uses a thick monofilament hook.</li> <li>■ Normal type</li> </ul>	
			SOFT type 1QS-N	Nylon	<ul style="list-style-type: none"> <li>■ Fish hook-shaped pile for reliable engagement.</li> <li>■ High-density pile with thin monofilament hook, softer to the touch, less skin irritation.</li> </ul>
				Polyester	<ul style="list-style-type: none"> <li>■ All polyester hook tape superior both in water repellency and UV-resistance.</li> </ul>
		MUSHROOM type 1QP-M	Nylon+PP	<ul style="list-style-type: none"> <li>■ Mushroom-shaped pile for reliable engagement.</li> <li>■ Ideal for applications requiring high strength and low cycle life.</li> </ul>	
		Injection	POWERHOOK® Button 1QI * * - *	Nylon Polyester PP	<ul style="list-style-type: none"> <li>■ Injected molded type hook in various shapes.</li> <li>■ The injected molded hook provides stronger shear and peel strength than woven hooks.</li> </ul>
			Continuous Injection	POWERHOOK® 1QE * * - *	PE POM
	Loop Tape (B)	Woven	NORMAL type 2QN-N 2QN-P	Nylon	<ul style="list-style-type: none"> <li>■ Mates with all hook tapes.</li> <li>■ Consists of unnapped loop pile.</li> <li>■ Provides higher shear strength.</li> </ul>
				Polyester	<ul style="list-style-type: none"> <li>■ All polyester loop tape superior both in water repellency and UV-resistance.</li> </ul>
		Knitted	NAPPED type 2QM-N	Nylon	<ul style="list-style-type: none"> <li>■ Mates with all hook tapes.</li> <li>■ Consists of napped loop pile.</li> <li>■ Stronger peel strength than normal type loop.</li> </ul>
			KNIT NAPPED type 2QK * * - *	Nylon	<ul style="list-style-type: none"> <li>■ Mates with all hook tapes.</li> <li>■ Tricot and circular knitted tapes available. Napped finish.</li> </ul>
Mixed (AB)	Woven	MIXED type (Q mate®) 4QNN-N	Nylon	<ul style="list-style-type: none"> <li>■ Hook and loop are intermingled on the same tape.</li> <li>■ No distinction between the hook tape and the loop tape.</li> </ul>	
		Back to Back type 5QN-N	Nylon	<ul style="list-style-type: none"> <li>■ Woven tape consisting of Hook on the face side and Loop on the back side.</li> </ul>	

Main Uses

- Apparel
- Bags, pouches, shoes, gloves, belts, tool cases, and sporting, leisure and amusement goods.
- Handicrafts, interior decoration items
- Trims and seats of automobiles, trains, and airplanes (fire-resistant type)
- Medical appliances such as corsets and tonometers

- Trims and seats of automobiles, trains, and airplanes (fire-resistant type)
- Sports goods, interior decoration items, furniture
- Industrial materials

- Interior decoration items such as curtains
- Automobile-related items
- Daily necessities such as cleaning tools
- Belts
- Industrial materials

- Apparel
- Bags, pouches, shoes, gloves, belts, tool cases, and sporting, leisure and amusement goods.
- Handicrafts, interior decoration items
- Trims and seats of automobiles, trains, and airplanes (fire-resistant type)
- Medical appliances such as corsets and tonometers

- Apparel
- Gloves, belts
- Bedclothes, interior decoration items

- Bonding use

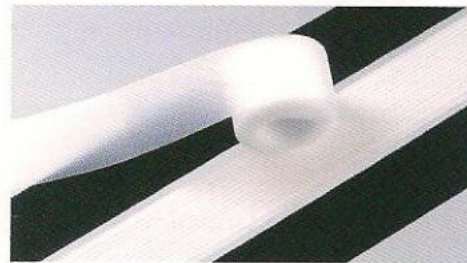
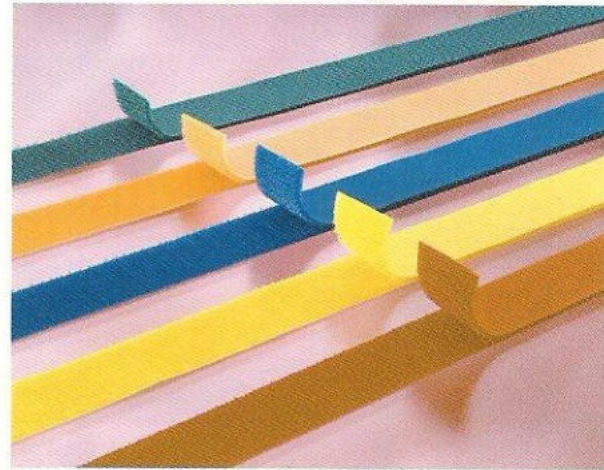

POWERHOOK®



MIXED type (Q mate®)

■ **cosmolon® Features**

<div style="background-color: #ccc; padding: 5px; writing-mode: vertical-rl; transform: rotate(180deg); font-weight: bold;">EARLY STRENGTH</div>	Soft	<b>Ultra Soft type</b>	1QSK-N × 2QKWC-N
	↑	<b>Super Soft type</b>	1QSAC-N × 2QKWC-N
	↓	<b>Soft type</b>	1QS-N × 2QKWM-N
	↓	<b>Normal type</b>	1QNN-N × 2QN-N
	↓	<b>Strong type</b>	1QF-N × 2QM-N
	Hard	<b>Mushroom type</b>	1QP-M × 2QKWM-N

<div style="background-color: #ccc; padding: 5px; writing-mode: vertical-rl; transform: rotate(180deg); font-weight: bold;">DURABILITY</div>	↓	<b>Normal type</b>	1QNN-N × 2QN-N
	Well	<b>Soft type</b>	1QS-N × 2QM-N

■ **cosmolon® Strength Test**

● **Tearing Strength Test**

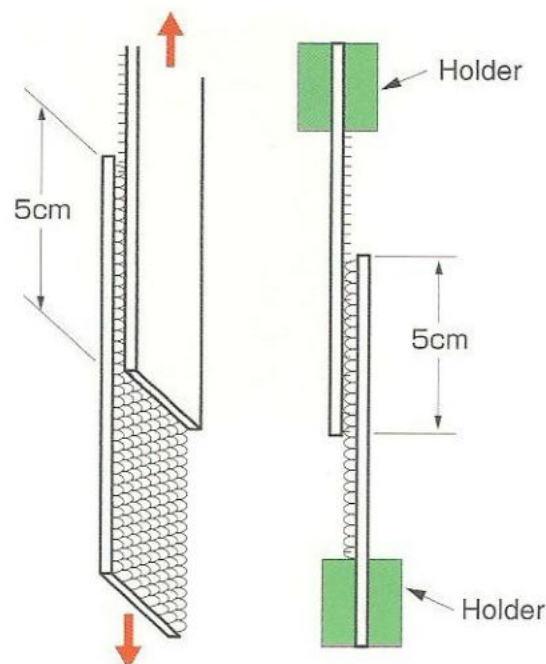

● **Peeling Strength Test**

(Under conditions of 20° c×65%RH fastened length of 50m/m)

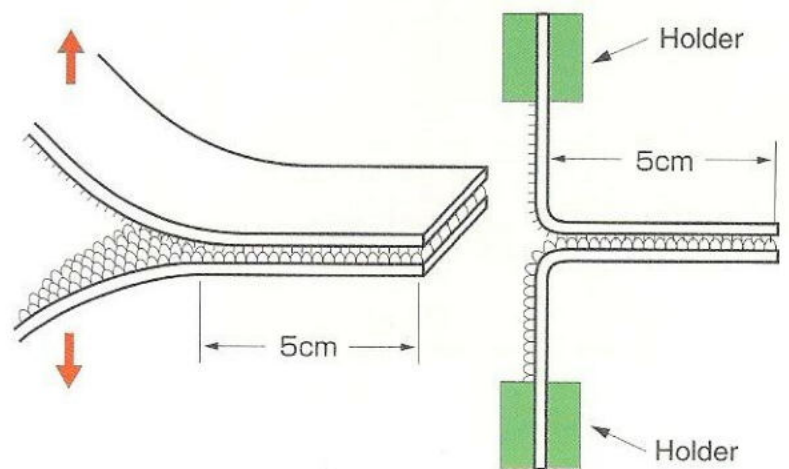

● Tested on the standard of JIS-L-3416-2000

## Special Products

WE type	Cosmolon used in high-frequency welding onto soft PVC sheet
WE-T type	Cosmolon used in high-frequency welding onto fabrics, textiles, etc.
AD type	Cosmolon with a double-sided adhesive tape on its reverse side for a temporary bond.
ADN type	Cosmolon with an acrylic-based adhesive on its reverse side for a temporary bond.※1
ADS type	Cosmolon with a rubber-based adhesive optimized for low energy surfaces, such as PP and PE.※2
HMPP	Cosmolon with a rubber-based adhesive optimized for low energy surface, such as PP and PE.

※1.ADN type is applicable to soft PVC, however the ADN can react with plasticizers, affecting bond strength.

※2.ADS type and HMPP is easily affected by plasticizers within soft PVC.Please refrain from using ADS type and HMPP on soft PVC substrates.

FP type	Fire retardant hook & loop fastener which satisfies the U.S. Federal Automobile Safety Standards FMVSS-302.
FA type	Fire retardant hook & loop fastener which satisfies the U.S. Federal Aviation Specifications, FAA-25-853 (b)
WS type	Back-to-Back type with ultra-sonic pattern bonding.
P- ( ) type	Cosmolon with printed surface.
( ) -G type	Cosmolon specially woven to prevent build up of electro/ static charge.
BD	Fabricated hook & loop in the form of straps.

## cosmolon® Sizes and Shapes

- Widths : 16, 20, 25, 50 and 100mm  
With the use of a slitter, COSMOLON can be used for widths other than the above.
- Put-up : 5m, 25m and 50m on spool  
Cut length : Any dimension  
Blanked shapes :  etc.

# Plastic Hardware

● A printed catalogue of Plastic Hardware is also available.

BUCKLE	BUCKLE	BUCKLE	BUCKLE	BUCKLE	CAM BUCKLE	STRAP ADJUSTER	STRAP ADJUSTER	LOOP
								
LB-MV	LB-WGS	LB-PTC	LB-XD	LB-FU	LA-CB	LK-WG	LK-E	LA-PYD
								
LB-MVD	LB-WS	LB-RS	LB-XK	LB-Q	LA-CBH	LK-WGS	LK-M	LA-PHA/PHB
								
LB-LV	LB-HL	LM-D/DB	LB-RC	LB-FW	LA-TS	LK-WL	LK-L	LA-DYB
								
LB-LVD	LB-PT	LM-DH/DHB	LB-PC	LB-FR	I.D. CARD HOLDER	LK-LV		LA-DXB
								
LB-LVS	LB-PTD	LB-R	LB-HC	LB-LB	LJ-H	LK-PT		LA-PYA/PYB
								
LM-LV	LB-PTS	LB-RD	LB-EG	WB-S		LK-U		LA-PXA/PXB
								
LB-U	LB-PTG	LB-RP	LB-ED	WB-H		LK-KU		LA-RH
								
LB-WG	LB-PTA	LB-RH	LB-S	WB-HS				LT-K
								
LB-WGD	LM-PT	LB-X	LB-F2	WB-DA				LH-E
								
				LM06TK				LT-TG

TRI-BAR ADJUSTER	SNAP HOOK	SNAP HOOK	TRI-RING	CORD STOPPER	CORD STOPPER	CORD HOLDER	ZIPPER COVER	CORD END	ZIPPER PULL
LA-S	LN-AR	LN-ZR	LD-TR	LC05MS1	LC05RW	LC10US	WZ-CO	LE03SV	
WEDGE ADJUSTER	LN-A	LN-Z	LD-TW	LC05MS2	LC05KH	LC05UG	WZ-SI/WZ05NI	LE03WV	IJ01SC
LH-W	LN-R	LN-KH		LC03MW1	LC05SL	LC02US	LZ05DLW	LE01STT	BELT ADJUSTER
CLIP	LN-E	D-RING		LC03MW2	LC05SC	LC02UC		LE03PB	5BS AABL
LA-AXA/AXB	LF-HA	LD-S		LC03MW3	LC05SB	LC02UH		LE05CE	3BR NR06
LA-AYA/AYB	LF-CH	LD-E		LC05SR	LC05WC	LC05EL		LE07CP	3BR NR08
LH-SG	LN-RE	LD-K		LC05KW	LC05WF			LE03CMT	TAPE END
LA20PS	LN-M	LD-RE		LC05HW	LC05HS			LE03PC	1QIBD-E
	LN-SX	LD-R		LC05HW	LC05HS			CORD INSERT PULLER	LE-B
				LC05SRS	LC05SRS			CP002A	LE-PW
								CP004A	



# Webbing Tape

The webbing tape were developed mainly for use in luggage and apparel. Please contact sales representatives if you require special strength and durability or if the tapes are to be used for any other special applications. Webbing Tapes used outdoor for prolonged periods fade and are weakened by exposure to ultraviolet rays. Please refrain from using in such applications.

## Pattern of weave by material (YKK's standard products)

### Polyester Woven Tape



TH Flat TB Herringbone TG Grosgrain TE Basket

### Polyester Knit Tape

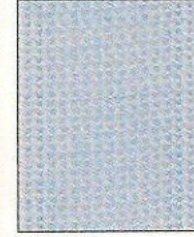

TN knit

### Reflective Tape

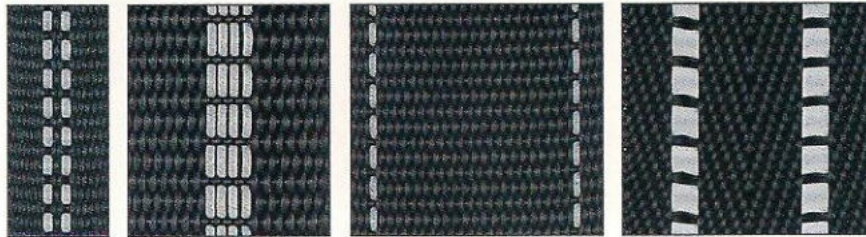

TX Flat PH Flat PH Flat PB Herringbone

### Urethane

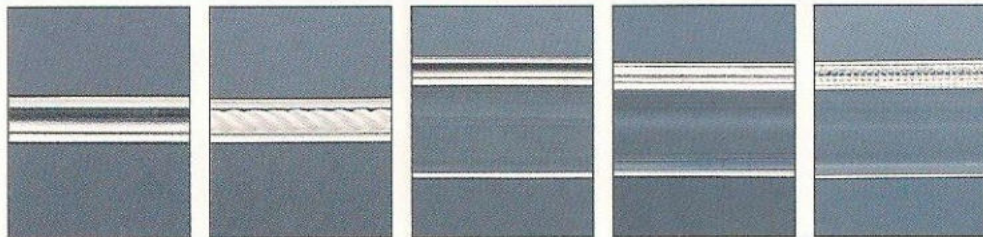

UC-S UC-C UP UP-R UP-RR

### Reflective Piping Tape



TP

## Webbing Tape Cut Processing

The width marked with "○" can be supplied in precut pieces.

Types of cuts	Cut shapes	Cut Tape Width					
		15	20	25	30	38	50
Straight cut		○	○	○	○	○	○
Diagonal cut			○	○	○		
One-side half-circle cut			○	○	○		
Both-end half-circle cut			○	○			

If you require tapes cut to special shapes please contact YKK sales representatives.

### Ultrasonic adhesion processing of tape and plastic parts.

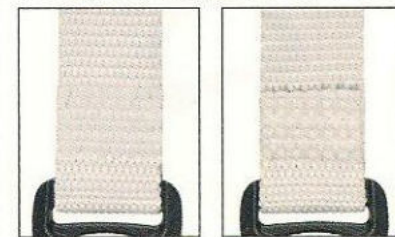

Front Back

YKK's ultrasonic technology provides high-quality adhesion finishing.

# YKK Manufacturing Plants

YKK Group 117 companies (Japan: 23, Oversea: 94)  
70 countries/regions (including Japan)  
as of 31st Dec, 2008



Kurobe Plant (Japan)



Tuen Mun Plant (Hong Kong)



Shanghai Plant (China)

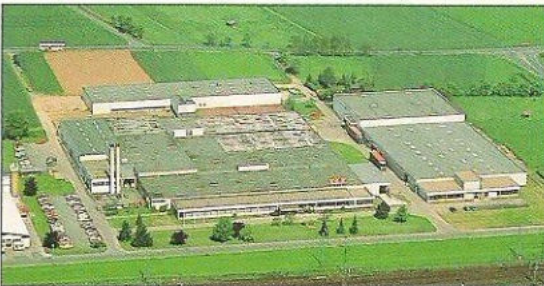

Marburg Plant (Germany)



Vercelli Plant (Italy)



Runcorn Plant (U.K.)



Lille Plant (France)

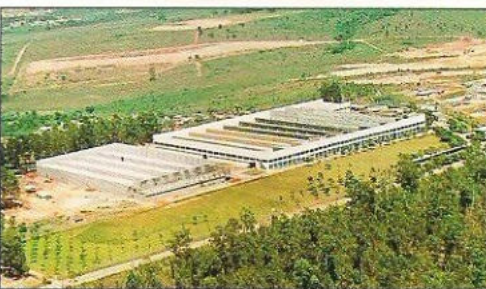

Sorocaba Plant (Brazil)

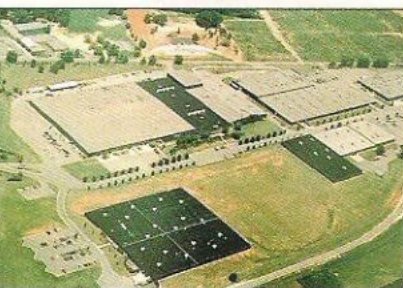

Macon Ocmulgee Plant/Ga. (U.S.A.)

## Names of Zippers Throughout the World

### ● SLIDE FASTENER

This English term refers to a sliding-clasp fastener and is used all over the world.

### ● ZIPPER or ZIP FASTENER

The word "zip" represents a very fast sound like a swish. By adding 'er', "zipper" has a connotation of something speedy. This word is popular in many countries, among them U.S.A. and Australia.

### ● CIERRES REPLAMPAGOS

This means "lightning" and is used in Central American countries.

### ● FERMETURE A GLISSIERE

French.

### ● REISSVERSCHLUSS

German.

### ● CHIUSURE LAMPO

Italian. "Chiusure" is the action of closing and "Lampo" means electric light.

### ● LA LIAN

Chinese. Used in China, Taiwan and Hong Kong.

### ● Chack

Used in Japan.

It was originally a Japanese tradename taken from "kinchaku", a traditional purse.

# History of Zippers and YKK

- 1891** An apparatus devised by an American named Whitcomb Judson to lessen inconveniences when tying shoestrings is considered to be the origin of the zipper.
- 1893** The apparatus was exhibited at the Columbia Exposition in Chicago, and captured the interest of Mr. Louis Walker, a lawyer. He ordered the manufacturing machines from the inventor and thereafter established Universal Fastener, Inc. With that, the production of zippers began.
- 1905** Zippers were improved and the one called "The Original" was developed by Mr. Judson. This became the prototype of the present-day zipper.
- 1917** Mr. Walker continues to study zippers with a Swedish engineer, Gideon Sundback and produced "Hookless No.4" successfully applying the zipper to a bellyband type wallet made by an apparel dealer in Brooklyn. They were also utilized in aviator uniforms of the U.S.Navy.
- 1921** B.F.Goodrich inc. incorporated zippers in their overshoes, and it was at this time that the name "zipper" was first used, thereafter becoming a popular term in America.
- 1927** In Japan, during this early Showa period, a man from Onomichi Hiroshima began making zippers, marketing them under the trademark "Chack Mark". The zipper was relatively strong and durable for this time so "Chack" became an synonym for zippers and the word is still widely used in Japan.
- 1932** Mass production of zippers began with handicraft-type manufacturing. Until then, hand presses had been used. When relatively advanced machinery, such as power presses were developed, zipper manufacturing took off.
- 1934** Zipper products began to be exported to Shanghai, Hong Kong, and South and Central America. San-S Company, the predecessor of Yoshida Kogyo K.K., was established in January of this year.
- 1937** Large quantities of zippers began to be exported to the United States and to South and Central America. The zipper industry became recognized as an emerging industry. However, most manufacturers were soon forced to give up or change their business, except a few who were authorized to supply goods to the army, when Japan entered the second world war in 1941.
- 1946** After the war, the station of US forces in Japan had a big impact on the boosted demand for zippers. However, the industry had been so badly damaged that it could not meet this demand, also the so called "Japanese manufacturing method" revealed its weakness of handicraft type manufacturing. The unfavorable image that zippers break easily was inherited at this time.
- 1948** When Swiss inventor George de Mestral went on a walk with his dog, he noticed that his dog's coat was covered with cockleburrs. It led him to study the burrs under a microscope, where he discovered their natural hook-like shape.
- 1950** Yoshida Kogyo K.K. imported the first automatic zipper chain making machine to Japan, and took the initiative in mechanization. With its original idea, YKK succeeded in developing an automatic slider manufacturing machine. YKK renovated Japan's zipper business by bringing innovative progress extending from production process to product management, and expelled all drawbacks of conventional production methods.
- 1951** A modern factory, matchless in this industry was completed with the operation of 30 chain machines manufactured in Japan.
- 1957** No.0, the world's smallest zipper, and a new Mitra zipper for trousers were put on the market and became a topic of conversation.
- 1958** Hidden zippers (CONCEAL<sup>®</sup>) appeared as a new product.
- 1959** L-type zigzag element zippers were introduced.
- 1961** 31 machines producing Zipper of Delrin<sup>®</sup> (Vislon<sup>®</sup>) were installed and these zippers were launched.  
※Delrin<sup>®</sup> is a Trademark of E.I.Du pont Co.,
- 1963** Woven zippers (EFLON<sup>®</sup>) appeared.
- 1964** Coil zippers were introduced.
- 1966** Y-type metal zippers (YZIP<sup>®</sup>) having an ideal element shape were sold.
- 1971** Coil zippers which used a knitted tape (BEULON<sup>®</sup>) were marketed for the first time.
- 1975** Delrin<sup>®</sup> zipper officially changed its name to VISLON<sup>®</sup> zipper.
- 1978** Zippers for fishing nets and new type of Woven in zipper (CFW) were brought out.
- 1979** Injection-Molded "with fin" zippers model VFF (VISLON<sup>®</sup>) and Watertight/Airtight zippers appeared.
- 1980** New type of Zigzag zippers (2SF) were introduced.
- 1981** New-type model EFR zippers (EFLON<sup>®</sup>) and the hook and loop fastener, "QUICKLON<sup>®</sup>" (COSMOLON<sup>®</sup>) were introduced.
- 1982** Injected zippers (45XF)
- 1983** Watertight/Airtight zippers (20VFF) were put on the market.
- 1984** Injected zippers (XF) (Woven in XWF), new type of VISLON<sup>®</sup> zippers (VFS), Sheet zippers (2SF) with clear tape and Quicklon<sup>®</sup> appeared.

- 1985** Watertight and airtight zippers (AWTIGHT®) were produced and marketed.
- 1986** Water resistant (8CWT) (double coil) and Side open VISLON® zippers were sold.
- 1987** Zippers with sophisticated discrete elements, "BALAZIP®", were put on the market for the first time.
- 1988** No.0, the world's smallest zipper, "MINIFA®" (0EF), Elastic Coil Zippers (5CNF) and JOYLON® (Rail fastener) appeared.
- 1989** Plated coil zippers were launched. (known for having a metallic appearance although made of plastic.)
- 1990** Graphic® series (Concealed zipper with jacquard woven design) zippers were sold.
- 1991** Hook & loop fastener "MOLD QUICKLON®" (mold type) were sold.
- 1992** The EVER BRIGHT® gloss-polished fastener, the VISLON® with thermal transferred metallic foil zipper, and the DIECAST INJECTION MOLDED zipper were launched.
- 1993** Hook & loop fastener "Q meshe®" (mesh type) , Hook & loop fastener "Q mate®" (pair type) , Hook & loop fastener "Q touch®" (curtain rail) were sold.
- 1994** The MOLD QUICKLON® (continuous injection-type) in broad-width, the marble tape zipper, and the light-accumulating zipper LUMIFINE® were introduced. On August 1, the company changed its name from "Yoshida Kogyo Co., Ltd." to "YKK Corporation".
- 1995** Lubricating spray exclusively for zippers FastenerMate® was introduced.
- 1997** Woven in zippers (65EY) for bags appeared.
- 1999** Clear Coil zippers (CL) were put on the market.
- 2000** GRADATION® zippers were sold.
- 2002** "Flat Knit®" (25FK) were sold.
- 2004** "Lumina®" were put on the market
- 2005** "ReEarth®" series appeared  
"AQUASEAL®" were introduced

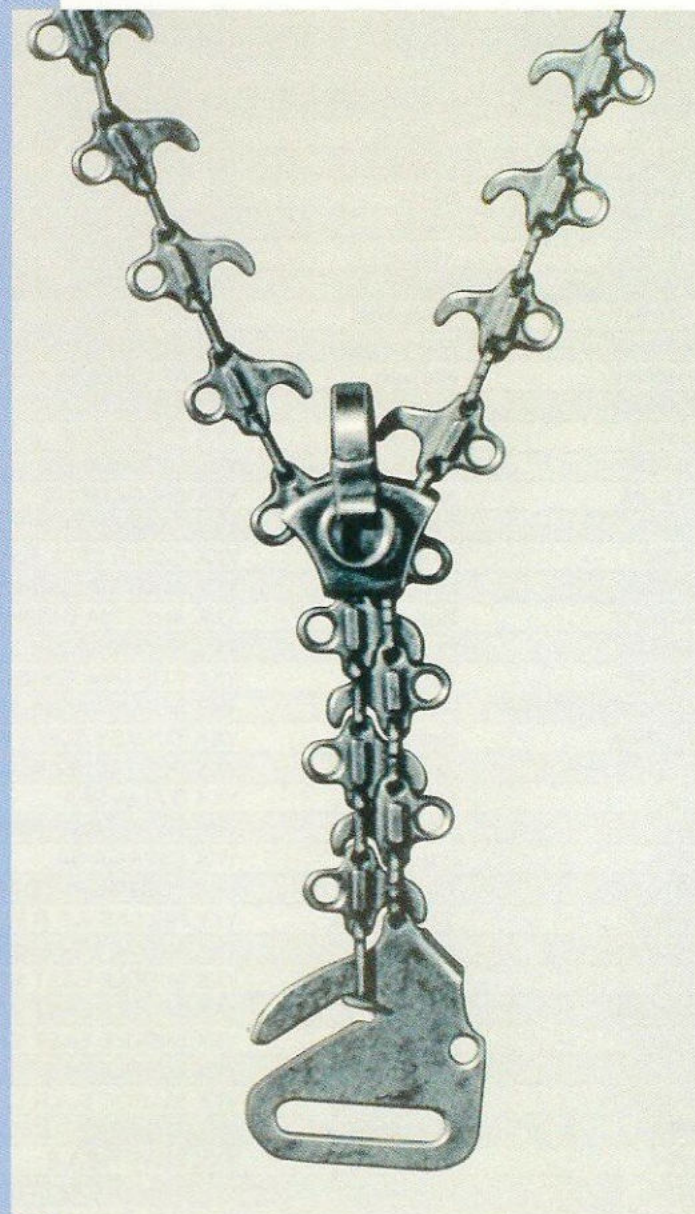

The first zipper in the world, called "The Original"



 YKK CORPORATION  
<http://www.ykkfastening.com>